

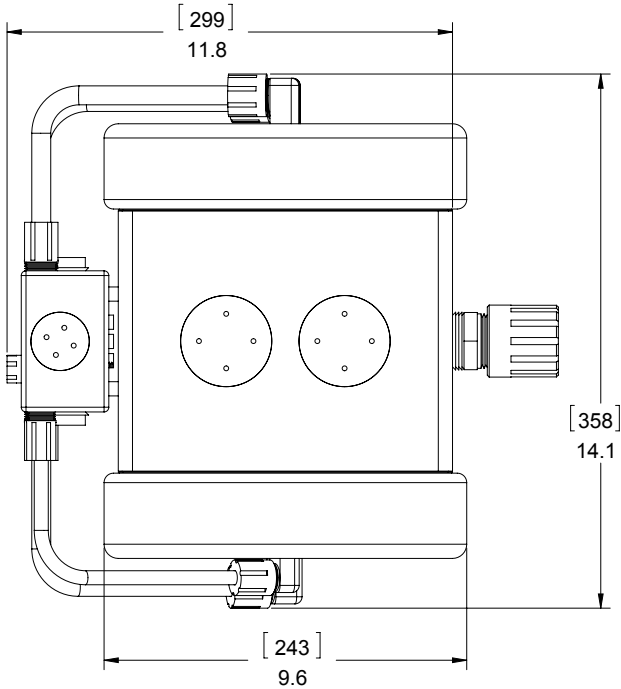

Pump Dimensions

DIMENSIONS IN [MILLIMETERS] INCHES



MOUNT WITH 2 EA.
3/8" (10 mm) SOCKET
HEAD CAP SCREW

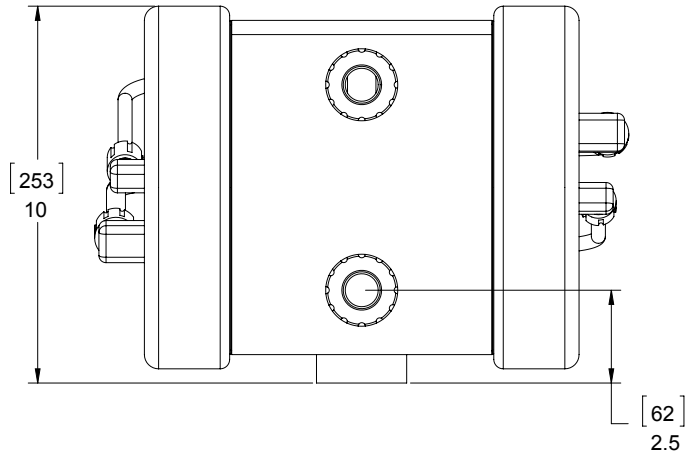
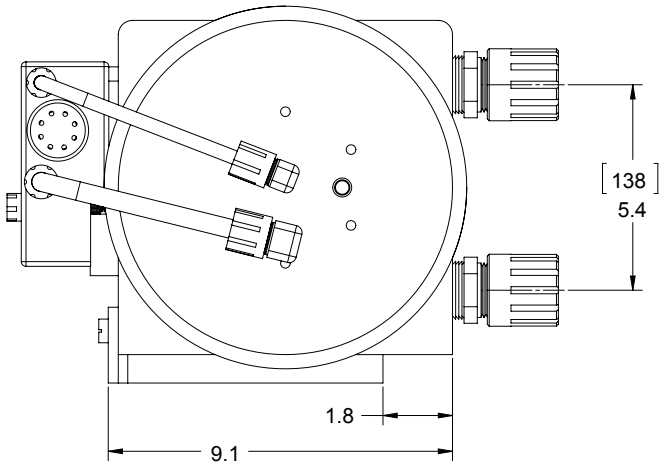
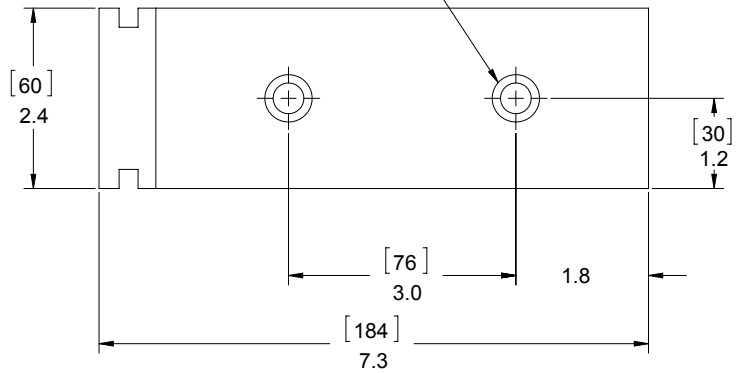

wkfluidhandling.com/at300hd

Our engineers are easy to work with and ready to perform your custom testing.
Contact us at info@wkfluidhandling.com or 435.783.6040, or visit wkfluidhandling.com

