

PSD04 3-għaliq Uħjb 3-għaliq Wħcbg



CE

Installation

Installation Precautions

Required Air Flow and Operating Pressure
Required Air Flow for the PSD04 is 3/16" minimum orifice unrestricted, up to 10 feet. Beyond ten feet a larger ID may be required. An adaptor is included for 1/4" NPT or 1/4" BSPT with all pumps, NPT or BSPT is decided on based on the liquid fittings requested. Max air supply for the PSD04 is 7 Bar (100 PSI).
Restriction of Liquid Inlet Line
Restricting the liquid supply of the pump forces the pump to work harder than normal and should be avoided whenever possible, especially when pumping viscous liquids. Attempting to operate the pump against a closed liquid inlet will cause serious damage to the pump, and will void the warranty. If you wish to slow or stop your pump this may be done by closing off the liquid outlet.
Supply Pressure Recommendations
The life of your pump may be extended significantly by operating your pump 30%-40% below redline operating supply pressures. The use of undersized regulators, valves, and supply lines can decrease pump performance and longevity significantly.
Orientation
White Knight does not recommend installing your pump in any position other than its upright position. Check valves within White Knight PSD pumps are actuated by gravity and/or flow and perform optimally in the upright position.
Failure Potential
It is possible that the diaphragm may fail. In such a situation it is possible that chemical could enter the air side of the pump, and may even escape through the muffler. In such a situation the muffler media must be replaced and the air side purged. White Knight recommends the implementation of a one way valve on the air side to protect air lines from contamination in the event of a diaphragm failure.
Muffler
Pump performance may be restricted in the event of a clogged muffler. Regular inspection of air lines and muffler media is recommended to maintain performance.
Product Testing
Each pump is tested before being packaged for shipment. White Knight recommends the flushing of each pump before servicing if water can contaminate the process.

PSD Installation Advantages

Head Pressure / Dead-Head
White Knight PSD pumps may be controlled by opening and closing the outlet of the pump and may be installed in any head pressure situation up to dead-head. Dead-head occurs when air supply pressure and the liquid line (head) pressure are equal. Dead-head conditions allow for no flow. Under dead-head conditions the PSD will cease to cycle (limiting wear) until conditions change allowing for flow.
Running Dry
White Knight PSD pumps are capable of running dry without damage other than normal wear to the pump. When a pump is run dry it cycles faster than normal, accelerating the rate of normal wear.
Passing Solids
All damage caused by passing solids (wafer shards, etc.) is coverable under warranty when your pump is used in conjunction with a White Knight Catcher™ pre-pump filter.

System and Pump Environment

Clean Dry Supply Air (CDA)
Operation of the point of 5 PSD04 requires class 4 quality air for particles, moisture, and oils. (maximum particle size 15 microns, 3° C Dew 5 mg/m ³) per ISO8573 – 1.
Flammable Solvents
PSD pump models other than the PSDTC and the PSDUC lines are not constructed from conductive materials. Any system used to pump flammable solvents should be properly grounded. A test from River's Edge on using isolative pumps to pump flammable liquids indicated that the liquid itself must be grounded and that other procedures should be followed. A copy of the test is available upon request from White Knight.
Abrasive Slurries
For slurry applications White Knight recommends use of the PSD UH pumps.
Pumping Liquids Near Boiling Point
The boiling point of a liquid is reduced under vacuum (suction) conditions. Due to the vacuum caused by a pump, liquid could boil in the inlet line of the pump when it is not boiling in the tank (or other supply reservoir). Placing the pump as close as possible to the tank and with as little vertical lift as possible (the pump being flooded by gravity is ideal) minimizes boiling in the inlet line. Boiling of the liquid in the inlet line causes a pump to “race” and accelerates the wear of the pump. Boiling liquids may cause cavitation to occur. Damage to wearable or non-wearable components of the pump caused by cavitation is not covered under warranty.
Running a Submerged Pump
When running the PSD in submerged mode, the exhaust air must be sealed and redirected above the surface of the media. Take care that all pump parts (air side and wet side) are resistant to the media being used. It may be necessary to mount the pump to the bottom of the tank. Operating this pump while submerged requires use of a remote muffler adaptor kit.
Temperature
The PSD may be operated safely in low temperature applications. Take care to avoid freezing or crystallization of the fluid inside or outside of the pump. Running the pump at temperatures below freezing may accelerate the wear of the elastomer components within the pump. In applications where the media or pump temperature varies, torque values (tension) of the manifold and head bolts must be monitored. TE versions of the PSD Series pumps can be operated at temperatures up to 100°C (212° F). UH versions of the PSD Series pumps can be operated at temperatures up to 70°C (158°F).

Control and Monitoring Connections

PUMP MONITORING: Pump monitoring can be performed by solid state pressure switch monitoring. This option is described on our website in the accessories section and is available for new orders and for retrofits in the field.

Conductivity Leak Detection



Pressure Switch Stroke

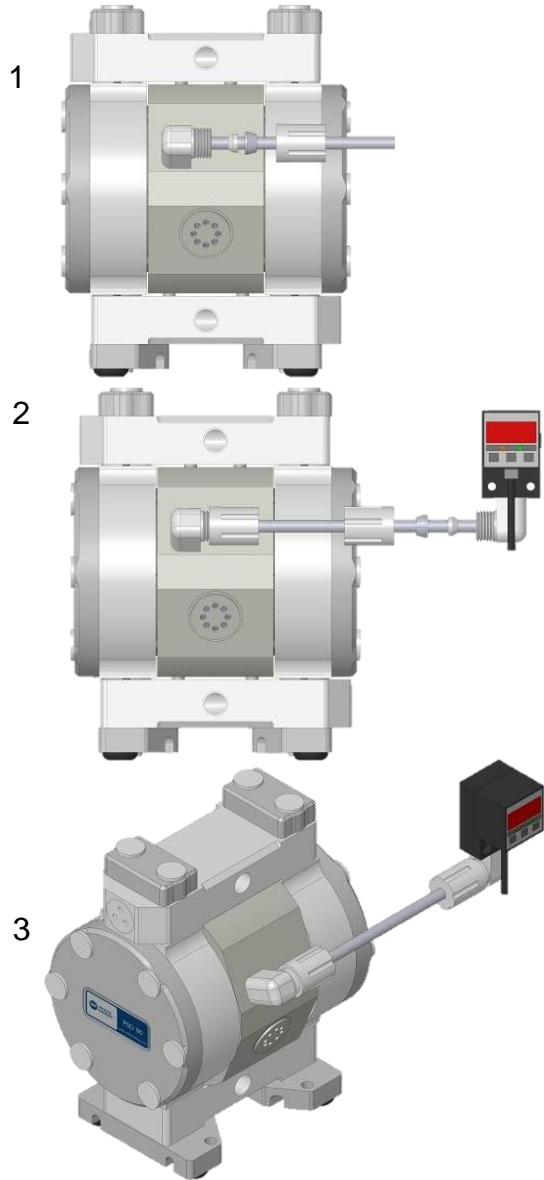

Pump Control: Run mode and flow rate are two of the items which the CPT-1 can control/monitor.



PSD04 Installation Instructions

1.



- Fix base plate to work station with four 3/8" or 10 mm bolts. (Bolts not included.)

2.

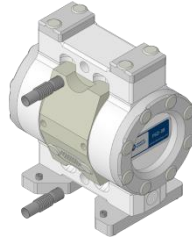

- Attach 1/4" liquid fittings to pump. Excessive force may damage threads.

3.

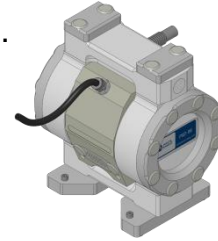

Adaptor is included for 1/4" NPT or 1/4" BSPT

- Ensure airline is free of solids before attaching. Supply air via 1/8" NPT air fitting with flexible connection.

Inlet/Outlet Configurations

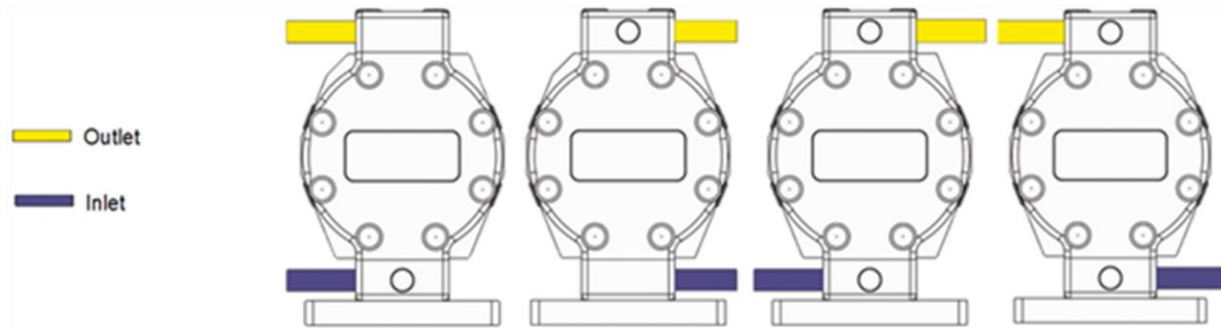

Some configurations require re-orientation of crossover manifolds. See Disassembly and Assembly Instructions.

Recommended Set Up

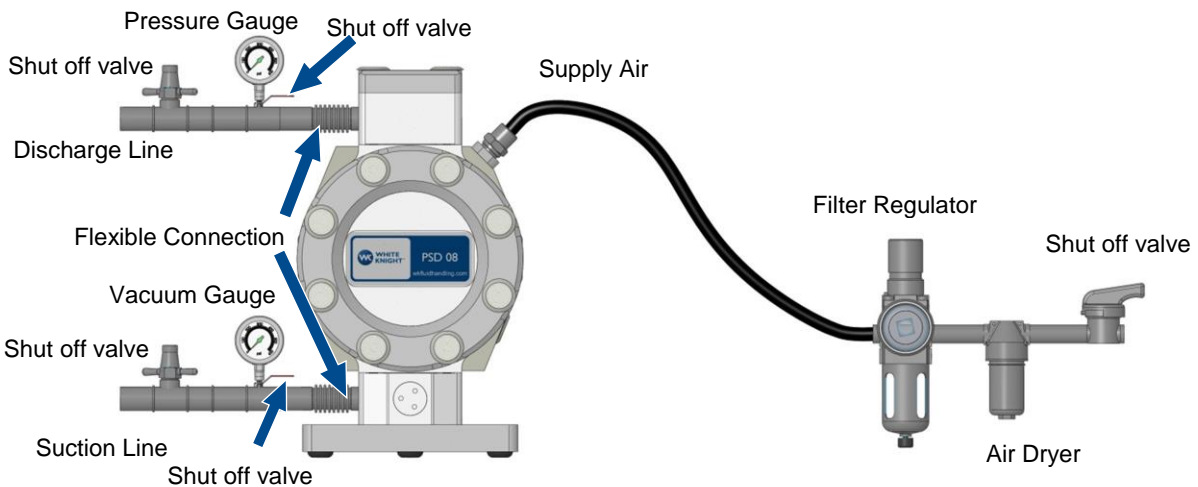

Caution: Closing suction line while pump is operating will cause irreversible damage to the pump.