

# IMTEC



## AHQD DUAL IN-LINE HEATER SYSTEMS MODELS 6000, 9000, 12000, 18000, AND 24000

### INSTRUCTION MANUAL

PART NUMBER 10-018-0048

**IMTEC by White Knight Fluid Handling**

187 East 670 South  
Kamas, UT 84036  
Telephone: (435) 783-6040  
Fax: (435) 783 -6128

*On the Web at: <https://wkfluidhandling.com/>  
Email: [customer.support@wkfluidhandling.com](mailto:customer.support@wkfluidhandling.com)*

**COPYRIGHT© 2025 White Knight**

All rights reserved. Any reprinting or unauthorized use without the written permission of WK IMTEC is expressly prohibited.

This document contains proprietary information of WK IMTEC and is tendered subject to the conditions that the information:

- be retained in confidence,
- not be reproduced or copied in whole or in part, and
- not be used or incorporated as part of any product, except under an express written agreement with WK IMTEC

All information in this document is subject to change without notice.

The information in this manual has been carefully checked and is believed to be accurate; however, no responsibility is assumed for inaccuracies or omissions.

References in this manual may describe optional equipment. Please contact an WK IMTEC sales representative for information about standard and optional equipment.

Manual Part Number:	10-018-0048
Release Date:	05/01/25

## Instruction Manual Revision History

Date	Section	Description
05/01/25	Entire Manual	Initial release of manual. Combined Models 6000, 9000, 12000, 18000 and 24000 into this one manual. Released new manual part number.
05/12/25	Inside front cover	Corrected support email to <a href="mailto:customer.support@wkfluidhandling.com">customer.support@wkfluidhandling.com</a>

## TABLE OF CONTENTS

### Title and Copyright Page

### Manual Revision History Page

### Preface

Intended Use of this Equipment.....	i
Intended Audience .....	i
Safety Considerations.....	i
Environmental Information .....	ii
General Safety .....	ii
Electrical Safety .....	ii
Chemical Safety .....	ii
Before Powering Up the Heater .....	iii
Cleanroom Requirements .....	iii
Customer Support / Emergency Contact .....	iii
Customer (EHS) Contact Information.....	iii
Preventive Maintenance .....	iv
Conventions Used in this Manual .....	iv
How to Use this Manual .....	v
WK IMTEC's Accuheat Limited Warranty .....	vi
Terms and Conditions .....	vi
Warranty Exclusions .....	vii
Damage Related to Shipment .....	vii
Packing .....	viii
In Conclusion .....	viii

## 1 Introduction

1.1 Overview – Basic Model.....	1-1
1.1.1 Power Modulators.....	1-4
1.2 Specifications.....	1-5
1.2.1 Environmental Specifications.....	1-5
1.3 Facilities Requirements.....	1-6

## 2 Safety Requirements

2.1 Emergency Contact .....	2-1
2.2 Electrical Safeguard Recommendations.....	2-2
2.3 In-Use Safety Precautions.....	2-2
2.3.1 Chemical Safety Requirements.....	2-4
2.3.2 Environmental Specifications .....	2-5
2.3.3 Power Modulator .....	2-5
2.3.4 Thermal Snap Switch Information .....	2-5

<b>3</b>	<b>Product Inspection</b>	
3.1	Unpacking Considerations.....	3-1
3.2	Inspecting the Packaging .....	3-1
3.3	Checking the Contents.....	3-2
<b>4</b>	<b>Installation Procedures</b>	
4.1	Emergency Off (EMO) Recommendations .....	4-1
4.2	Controller Recommendations .....	4-1
4.3	Plumbing Recommendations .....	4-2
4.4	Installation Procedures .....	4-4
4.4.1	Installing the Power Modulator .....	4-4
4.4.2	Installing the Accuheat In-Line Heater .....	4-5
4.4.2.1	Horizontal Installation.....	4-5
4.4.2.2	Vertical Installation.....	4-6
4.4.3	Connecting the Power Modulator .....	4-7
4.4.4	Connecting the Heater Power and Sensors .....	4-8
4.4.5	Connecting the Heater Plumbing .....	4-9
4.4.5.1	Installing the Fit-One plumbing nuts.....	4-10
<b>5</b>	<b>Operating Instructions</b>	
5.1	Safety Precautions .....	5-1
5.2	Controls and Indicators .....	5-3
5.3	Ramp-Up .....	5-3
5.4	Shut-Down .....	5-4
<b>6</b>	<b>Troubleshooting and Maintenance Procedures</b>	
6.1	Troubleshooting Procedures.....	6-1
6.2	Maintenance Procedures .....	6-3
6.3	Removing the Heater .....	6-3
6.4	Return Authorization Procedures .....	6-4
6.4.1	Return Policies .....	6-4
6.4.2	Obtaining a Return Authorization Number .....	6-5
6.4.3	Packing the Heater for Return or Decommissioning .....	6-5

## Updates

### NOTE

The Updates section will be empty if this is the Initial shipment of this manual. Updates will follow at the discretion of WK IMTEC.

## PREFACE

This preface includes the following topics:

- Intended use and audience
- Basic safety considerations
- Customer support
- Conventions used in this manual
- How this manual is organized
- Standard WK IMTEC Accuheat warranty
- Table of contents

<b>CAUTION</b>	
	<p><b>USING IMPROPER CONFIGURATION VALUES CAN CAUSE PRODUCT OR EQUIPMENT DAMAGE</b></p> <p>Do not enter set-up or configuration values outside the specified range for any given heater or optional device. To do so may seriously damage your product or equipment.</p>

### Intended Use of this Equipment

WK IMTEC's Dual In-Line Heater Accuheat Systems are not to be used for any purpose other than for which they were designed. What product is to be produced and how the heater and any optional equipment are to be configured for the allowed processing chemicals and parameters are stated in this Instruction Manual.

### Intended Audience

The level of detail in this manual assumes you have previously been trained to install, operate and maintain these systems.

This document supplements that training and addresses the comprehensive needs of Process Engineers and Maintenance personnel. After reading and understanding this information, Process Engineers are responsible for disseminating the appropriate level of information to their Equipment Operators.

### Safety Considerations

Your company's policies and procedures for safely operating any of the Dual Tube Accuheat Systems supersede the safety considerations listed below. It is your responsibility to follow your company's safety procedures. If there are none, follow those established by OSHA, NEC, DEQ, and/or the DOT, as a minimum.

## Environmental Information

The following laws and regulations are applicable to the operation and maintenance of WK IMTEC's Dual Tube Accuheat Systems.

- Air Emissions are regulated under the US Clean Air Act and local regulations applicable to the emissions of acids, bases and organic compounds.
- Wastewater emissions are regulated under the US Clean Water Act and applicable local pretreatment regulations.
- Solids contaminated with acids and other chemicals are regulated as hazardous wastes.

## General Safety

- Never open or disassemble the heater tube. There are no serviceable parts inside the heater enclosure.
- Do not attempt to work on or with hazardous chemicals or electrical equipment without proper safety training, certification, and personal protective equipment.
- Lockout and tag the electrical and/or chemical systems before any repair or replacement tasks. Refer to this Instructions Manual for this equipment and your company's safety policies and procedures for repair instructions.
- Before attempting any procedures, know how to perform emergency first aid response for electrical shock and spills of hazardous chemicals.
- Review & understand emergency escape routes to safe areas.

## Electrical Safety

- During periods of lightning activity, do not connect or disconnect any cables or perform installation, maintenance, or reconfiguration.
- Before attempting any procedures, locate the main electrical source and understand how to safely control it.
- Whenever possible, disengage the heater and optional devices from their electrical sources before attempting repairs.
- Notify nearby personnel that you are attempting to operate or service this equipment. Follow your company's lockout and tagout operating procedures.

## Chemical Safety

- Never attempt operations or repairs involving hazardous chemicals alone. Always have another person within sight and voice range.
- Protect eyes, face, hands, and body with appropriate personal protective equipment.

### Before Powering Up the Heater

- Understand the system's alarm indications and automatic system interlocks (refer to Section 2, *Safety Requirements*).
- Ensure that all safety devices in the work area are properly installed and functional.

### Cleanroom Requirements

Specific cleanroom requirements can vary widely according to the class rating, i.e., Class 10, Class 100, etc. WK IMTEC’s products qualify as Class 1. While performing maintenance or operating the system, follow your company's policies and procedures for this equipment.

### Customer Support / Emergency Contact

In the case of emergency or equipment failure, refer to the **Emergency Contact Form** (under separate cover).

For assistance in operating, troubleshooting, or maintaining your heater refer first to this and any other manuals supplied to you by WK IMTEC. If these manuals do not address your specific needs and questions, please contact WK IMTEC Customer Service:

<p><b>WK IMTEC Acculine</b> 187 East 670 South Kamas, UT 84036</p>	<p>Phone: (435) 783-6040 Fax: (435) 783-6128</p>
<p>Email:customer.support@wkfluidhandling.com</p>	<p>From 8:00 a.m. to 5:00 p.m., MST, Monday through Friday</p>

When calling, please be at the system, if possible, and be prepared to give a detailed description of the problem.

### Customer (EHS) Contact Information

In the event that WK IMTEC needs to contact the customer regarding EHS issues related to the Accuheat In-line heater, they will use the contact provided on the Purchase Order or that provided on a returned warranty registration card. In the event the equipment is moved to a different location you can send new contact information via mail to WK IMTEC’s address above. Please note company name, address, product serial number, and contact information.

<b>NOTE</b>
Review your contract warranty statements regarding specific instructions for receiving help.





## Preventive Maintenance

Other than a weekly visual inspection for leaking connections, there are no preventive maintenance schedules or procedures.

## Conventions Used in This Manual

1. The word “WARNING” when used in warning boxes is defined as: **IMPROPER USE OF THIS EQUIPMENT CAN CAUSE SEVERE INJURY OR PRODUCT DAMAGE!**
2. The word “CAUTION” when used in warning boxes is defined as, **POTENTIAL PRODUCT OR EQUIPMENT DAMAGE!**
3. The following **WARNING** and **CAUTION** boxes are samples used to identify potential hazards that could occur if the heater is used improperly or if unsafe practices are followed.

<b>WARNING</b>		
	<p><b>IMPROPER USE OF THIS EQUIPMENT CAN CAUSE SEVERE INJURY OR PRODUCT DAMAGE!</b></p> <p>To ensure operator, equipment, and product safety, follow the instructions and use care when operating this equipment.</p>	

<b>CAUTION</b>	
	<p><b>POTENTIAL PRODUCT OR EQUIPMENT DAMAGE!</b></p> <p>Equipment or product damage can occur if care is not taken.</p>

A **NOTE** box highlights special information.

<b>NOTE</b>
<p>Specific information is placed in a NOTE box when clear procedural understanding is essential.</p>

The following conventions are used throughout the manual:

**Data entries on pictured control screens or menus.** Unless stated otherwise, all example values on pictured data entry screens are for display purposes only and were not intended to be considered as recommended values for your equipment.

**Boldface text** indicates the actual words used in a screen command or on an equipment label.

## How To Use This Manual

The level of detail in this manual, and listed below, covers the necessary information to install, operate, maintain, and service Dual Tube Accuheat Systems.

**Instruction Manual Revision History Page:** details any changes made to the manual, the date the change took place, and what specific information was changed, added or deleted. If changes or updates are added to your individual manual, a new Revision History Page will be sent to you along with those changes.

**Preface,** includes the intended use and audience, basic safety considerations, customer support, conventions used in this manual, how this manual is organized, standard WK IMTEC Accuheat warranty, and a table of contents.

**Section 1, *Introduction*,** is a description of the various models for the Accuheat Dual Tube Systems including: a theory of operations, specifications, and facility requirements.

**Section 2, *Safety Requirements*,** is a detailed description of all safety features and their functions and interactions.

**Section 3, *Product Inspection*,** lists the procedures for inspecting and unpacking the Accuheat Dual Tube Systems and optional equipment.

**Section 4, *Installation Procedures*,** included is a set of drawings indicating the connections to be made specific to your system.

**Section 5, *Operating Instructions*,** gives instructions on how to operate the heater and optional equipment after installation.

**Section 6, *Troubleshooting and Maintenance Procedures*,** covers typical troubleshooting techniques, maintenance schedule and procedures. If the heater needs to be returned for servicing this section give instructions for removing the heater for preparation for repair.

**Updates.** In the event new information is required, such as, corrections or updates after shipment of this documentation, WK IMTEC will send this new information to you. Upon initial shipment of this manual this section will be empty.

## WK IMTEC's Accuheat In-Line Heater Limited Warranty – (Non-Warranty of Merchantability, Fitness and Limitation of Liability)

### Terms and Conditions

1. WK IMTEC warrants the Accuheat In-Line Heater, whether new or remanufactured, to be free from manufacturing defects in materials and workmanship for a period of **two years** from the date of original shipment from our factory, with the following exceptions:
  - **Phosphoric Acid Applications: Since the etching of quartz by Phosphoric Acid is highly dependent on the mode of operation and control scheme, the warranty of the heater against failures caused by chemical etching in this application is one year from date of shipment.**
  - WK IMTEC quartz ware is guaranteed to remain sound and whole in normal usage for a period of 45 days from the date of initial shipment.

#### NOTE

“Remanufactured” applies to the complete rebuilding of a customer-owned Accuheat unit to new in-line heater specifications, including heaters, cable attachments, insulation and the like.

2. This Warranty, with the exception noted above, is limited as follows: In the event of a defect, WK IMTEC agrees, at its option, to repair or replace the defective unit or refund the purchase price and WK IMTEC's liability is limited thereto. Heaters repaired or replaced under warranty will bear the remainder of the original equipment warranty.
3. All repairs must be made at WK IMTEC's place of business. Buyer pays the cost of returning the product to WK IMTEC's factory. Any such return must be pre-authorized by WK IMTEC using issuance of an WK IMTEC Returned Materials Authorization (RMA) number. The RMA number must be displayed on the returned merchandise. It is the buyer's responsibility to retain the original packing materials or to obtain authorized replacement packing materials from WK IMTEC should the heater ever need to be returned to the factory. Refer to Section 7, *Maintenance Procedures*, for the Returned Materials Authorization procedures.
4. The period of warranty commences as of the date of shipment from WK IMTEC.

## Warranty Exclusions

While other Exclusions may apply, WK IMTEC specifically does not guarantee, and accepts no responsibility for the following:

- Failure caused by incorrect plumbing: for example, installing with flow opposite to the direction indicated in this manual and on the Accuheat housing, or with piping elevations that may result in vapor-lock to the outlet flow.
- Corrosion of the quartz components by non-compatible chemistries such as hydrofluoric acid and potassium hydroxide.
- Damage as a result of misuse of the WK IMTEC-supplied Power Modulator.
- Etching is not covered if the appropriate power modulator is not installed and used.
- Damage as a result of operating the Accuheat outside the specified limits.
- Customer modifications to the housing, electrical circuitry, safety sensors and/or accessories;
- Improper transportation, handling, or installation damage, including, but not limited to, insufficient air gap around the perimeter of the Accuheat; insufficient support of plumbing lines, creating stress on the plumbing connections; use of plumbing nuts other than those supplied with the unit; placement of the Accuheat in a corrosive environment; immersion of the Accuheat in water or other fluids.
- Unauthorized customer modification to any portion of the system.

### NOTE

Unauthorized customer modification(s) may void all warranties.

## Damage Related to Shipment

It is the buyer's responsibility to carefully inspect each quartz Accuheat In-Line Heater upon receiving it and to determine if any breakage has occurred during shipping. Claims for quartz found broken in shipment are not the responsibility of WK IMTEC and should be submitted to the freight carrier. WK IMTEC recommends such claims be submitted within 5 days of Receipt of Shipment.

## Packaging

It is the buyer's responsibility to retain the original packing materials or to obtain authorized replacement packing materials from WK IMTEC should the equipment ever need to be returned to the factory.

## In Conclusion:

### NOTE

**WK IMTEC does not warranty merchantability or fitness for any purpose and there are no warranties expressed or implied other than those expressly stated in this document. WK IMTEC is not responsible for any consequential, incidental or other damages whatsoever. WK IMTEC's liability is limited to the repair or replacement of such defective product OR refund of purchase price, at WK IMTEC's sole option, as stated above. All claims must be made in a timely manner and within the warranty period to be considered valid. Please contact WK IMTEC at:**

**WK IMTEC® Acculine**

**187 East 670 South**

**Kamas, UT 84036**

**Telephone: (435) 783-6040**

**Fax: (435) 783-6128**

**On the Web at: [www.wkfluidhandling.com](http://www.wkfluidhandling.com)**

**E-mail: [info@wkfluidhandling.com](mailto:info@wkfluidhandling.com)**

# 1 INTRODUCTION

This section describes the WK IMTEC Accuheat AHQD Dual Tube series of In-Line Heaters. This series includes the Model 6000, 9000, 12000, 18000, and 24000. This section includes the following information:



- Overview of Basic Models
- Components Overview
- Specifications
- Facilities Requirements

## 1.1 Overview – Basic Model

The Accuheat AHQD Dual Tube model is an efficient in-line heater combining low cost-of-ownership with an extended service life. These models have all-quartz heated surfaces for process purity and can be applied to a number of uses, including filtered RCA cleans, DI water heating, photoresist-strip recirculation, nitride etch recirculation heating or pre-heating, and the heating of any chemical which is quartz-compatible.

These heaters conductively transfer heat for better efficiency and their low-mass heater arrays minimize temperature overshoot. The fluid flow pattern is designed for optimal heat transfer, so the Accuheat can be used for both high-flow and low-flow applications.

The heater module can be interconnected with other Accuheat modules to provide an optimum configuration for temperature rise, fluid flow and three-phase electrical load balancing. A special version of the WK IMTEC Model 951 Controller is also available for process control.

## **Product Bulletin**

**August 10, 2009**

**Product Line: ACCUHEAT**

**Models Covered: All Quartz Models**

**Imtec has had independent laboratory life time testing of its Quartz Inline heater product line, the ACCUHEAT, for chemical compatibility of NH<sub>4</sub>OH and water at temperatures up to 60degrees centigrade,.**

**Two concentrations were tested: 1:5 and 1:16 NH<sub>4</sub>OH and water @ 60 & 80 degree centigrade.**

**Both tests showed some degradation of the quartz material over a period of 8 hours. By extrapolating the resulting data into a projected yearly basis (continuous operation) these products are expected to have a life expectancy of 18-24 months.**

**Based on these results WK Imtec has approved the use of these products under the following conditions:**

**Heater Type: All Quartz Accuheat products**

**Maximum Media Concentration: 1:5 NH<sub>4</sub>OH and Water (Max PH Value 12.5)**

**Maximum Operating Temperature: 60 C**

**Projected Life Time Expectancy: 12-18 months- concentration dependent**

**(Product must be changed after 12 months of usage)**

**Warranty period: 12 months on Quartz Tube assembly and 24 months for all other parts.**

## Product Bulletin

Sept. 29, 2009

Product Line: ACCUHEAT

Models Covered: All Quartz Models

WK Imtec has used an independent laboratory to perform quartz compatibility testing when using various solutions of Ammonium Hydroxide and water at temperatures up to 60 degrees centigrade. The purpose of these controlled tests was to certify NH<sub>4</sub>OH and H<sub>2</sub>O chemistries when using any of WK Imtec's Quartz Accuheat Inline heater products.

Two concentrations were tested: 1:5 and 1:16 NH<sub>4</sub>OH and water @ 60 & 80 degree centigrade.

Both tests showed some degradation of the quartz material over a period of 8 hours. By extrapolating the resulting data into a projected yearly basis (continuous operation) these products are expected to have a life expectancy of 18-24 months.

Based on these results WK Imtec has approved the use of these products under the following conditions:

Heater Type: All Quartz Accuheat products

Maximum Media Concentration: 1:16 NH<sub>4</sub>OH and Water

Maximum Operating Temperature: 65 C

Projected Life Time Expectancy: 12-18 months- concentration dependent (Product must be changed after 12 months of usage)

Warranty period: 12 months on Quartz Tube assembly and 24 months for all other parts



### 1.1.1 Power Modulators

The basic purpose of power modulators is to extend the life of the heater application. There are two options for power modulators. The standard power modulator is designed for all processing applications with an operating setpoint temperature of 375°C.

The second power modulator is designed for use with Hot Phosphoric applications with an operating setpoint temperature of 300°C. This lessens the etching effect of the quartz tube.

The purpose of either power modulator is to allow the heater to provide as much heat to the process fluid as it can absorb without overheating when properly installed internal to the electrical enclosure.

Since process temperatures vary with the type of liquid and flow rate the WK IMTEC heater is capable of providing the maximum amount of heat for any application. When heat is applied beyond where it can be absorbed, the element temperature rises. When the heat reaches the setpoint of the power modulator, the signal to a correctly wired power relay is interrupted until the element temperature drops down below the setpoint where it once again allows the power relay to energize.

The standard Power Modulator is for use with chemistries that do not etch quartz. The setpoint is optimized to get the most efficiency out of the heater. The Hot Phosphoric Power Modulator has a lower setpoint to reduce the etching effect that occurs when the surface temperature exceeds 155°C. This allows the heater to have a much longer life, while having only a minimal effect to heat-up time.

It is important to know that the surface temperatures where the chemistry contacts the quartz will be much higher than in the process vessel or other parts of the recirculation loop. Another factor to apply the Hot Phosphoric power modulator is that Hot Phosphoric is very viscous at lower temperatures. That means that during heat-up, where the power modulator typically sees action, the flow rate is usually much lower than it is with, for instance, water or SC-1. This means that heat cannot be absorbed as fast so a lower modulator setpoint more accurately reflects the maximum amount of heat that the liquid can absorb.

## 1.2 Specifications

The specifications included in this section are for general use only. A model specific drawing and schematic is included with each heater. Refer to these drawings when working with the heater.

### 1.2.1 Environmental Specifications

Environmental Temperature	Indoor use only at 5°C to 40°C
Environmental Humidity	Maximum relative humidity is 80% for temperatures up to 31°C, decreasing linearly to 50% relative humidity at 40°C.
Altitude	Up to 2000 meters (6561.66 feet).
Supply Voltage	MAINS supply voltage fluctuations up to $\pm 10\%$ of the nominal voltage. Transient over voltages typically present on the MAINS supply.
Pollution	Applicable rated pollution degree 1

### 1.3 Facilities Requirements

The following facilities requirements are model dependent. While reading this section ensure you are referencing your model.

Facilities Requirements		
Model	Accuheat Power	Current Draw
<b>Model 6000</b>	208V (AC 1 $\phi$ ) 50/60 Hz.	29
<b>Model 9000</b>	208V (AC 3 $\phi$ ) 50/60 Hz.	25
<b>Model 12000</b>	208V (AC 3 $\phi$ ) 50/60 Hz.	33
	400V (AC 3 $\phi$ ) 50/60 Hz.	18
<b>Model 18000</b>	400V (AC 3 $\phi$ ) 50/60 Hz.	26
<b>Model 24000</b>	208V (AC 3 $\phi$ ) 50/60 Hz.	67
	480V (AC 3 $\phi$ ) 50/60 Hz.	29
<b>Modulator Power</b>	<b>Input</b> is 24VAC $\pm$ 10%, 50-60 Hz $\pm$ 5%, 10 VA (watts) maximum power consumption. <b>Output</b> is 8 amps at 240VAC or 30 VDC maximum resistive load or 250VA pilot duty, 120/240 VAC maximum inductive load.	

This concludes Section 1, *Introduction*.

## 2 SAFETY REQUIREMENTS

The following recommendations and requirements are included for personal and equipment safety. Please read them completely before installing and operating your Accuheat in-line heater system.

### NOTE

These recommendations are advisory in scope. **WK IMTEC assumes no responsibility for the correct or incorrect installation or use of this equipment in any user's facility.** WK IMTEC recommends that installation of this equipment be confined to licensed contractors, OEM-provided personnel and/or trained Facility Maintenance personnel.

Ensure you are familiar with your company's Equipment Safety Regulations and Specifications, the local fire marshal codes and applicable electrical code requirements for compliance.

### CAUTION



#### USING IMPROPER CONFIGURATION VALUES CAN CAUSE PRODUCT OR EQUIPMENT DAMAGE

Do not enter set-up or configuration values outside the specified range for any given heater or optional device. To do so may seriously damage your product or equipment.

WK IMTEC's Dual In-Line Heater Accuheat Systems are not to be used for any purpose other than for which they were designed. What product is to be produced and how the heater and any optional equipment are to be configured for the allowed processing chemicals and parameters are stated in this Instruction Manual.

### 2.1 Emergency Contact

In the case of emergency or equipment failure, refer to the **Emergency Contact Form** (under separate cover). For assistance in operating, troubleshooting, or maintaining your heater refer first to this and any other manuals supplied to you by WK IMTEC. If these manuals do not address your specific needs and questions, please contact WK IMTEC Customer Service:

<p><b>WK IMTEC Acculine</b> 187 East 670 South Kamas, UT 84036</p>	<p>Phone: (435) 783-6040 Fax: (435) 783-6128</p>
<p>Email: <a href="mailto:customer.support@wkfluidhandling.com">customer.support@wkfluidhandling.com</a></p>	<p>From 8:00 a.m. to 5:00 p.m., MST, Monday through Friday</p>

When calling, please be at the system, if possible, and be prepared to give a detailed description of the problem.

## 2.2 Electrical Safeguard Recommendations

Refer to this section and the attached schematics for electrical safety information. If you are using a non-WK IMTEC controller, refer to the controller manufacturer's documentation for electrical safety information and recommendations.

The Equipment that this heater will be installed in must have a Semi S2-approved EMO circuit, where *“the EMO actuator (button), when activated, must place the equipment into a safe shutdown condition, without generating any additional hazard to personnel or the facility”*. The EMO actuator is required to be installed in close proximity to the equipment and within easy reach of the operator and is required to be marked as a disconnect device according to S2-approved regulations.

All Dual Tube heaters have multiple heater elements. If you are using one circuit breaker and/or control relays for multiple elements, the rating of the breaker may exceed the current capacity of the heater wiring. Where this occurs, the elements should be individually protected by a fuse or other appropriate protection device. It is the responsibility of the customer to ensure that all wiring in the circuit is properly rated and protected.

<b>WARNING</b>	
	<p style="text-align: center;"><b>DANGEROUS VOLTAGE IS PRESENT!</b></p> <p>Hazardous voltages exist. To minimize risk of electrical shock, do not open the heater housing. Use caution around exposed circuits. Check area for exposed contacts prior to contacting this equipment.</p> <p>To ensure operator, equipment, and product safety, use care when operating this equipment. The following warnings must be adhered to.</p> <ul style="list-style-type: none"> <li>• The Accuheat comes with safety devices. For your safety and to ensure the Accuheat works as designed, do not disconnect or modify them. Report any malfunctions to WK IMTEC Customer Service.</li> <li>• The heater's housing is made of TFE Teflon: avoid any chemicals that could attack this material.</li> <li>• The use of a GFCI protection device is required for safe operation of the In-Line Heater. The reference ground provided is not intended for use as a safety ground.</li> <li>• Some heater models use multiple heater elements that may be powered from a common electrical supply. In this case the current rating of the supply circuit breaker may exceed the current rating of the individual heater wires. Where this is the case, each heater element must have its own circuit protection.</li> </ul>

## 2.3 In-Use Safety Precautions

<b>CAUTION</b>	
	<p style="text-align: center;"><b>HOT SURFACES!</b></p> <p>Surfaces may be as hot as 200°C. Do not move the heater or touch the hot surfaces of the heater.</p>



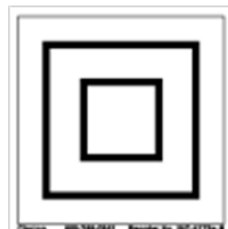
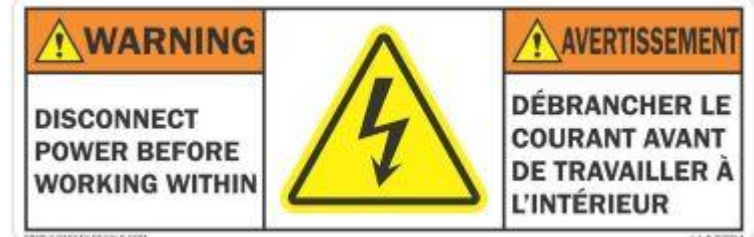

The following warning labels are placed on the equipment. Adhere to these safety labels. Do not exceed the label's recommend operating pressures or temperatures.





The In-Line Heater must be enclosed in a secondary containment area that will hold 110% of the fluid in the entire recirculation system including the process vessel. It is strongly advised that this enclosure be protected with interlocks to prevent operation if the enclosure is not properly sealed.

Read, understand, follow and implement the following general warnings and cautions during the use of this system.

GENERAL WARNINGS	GENERAL CAUTIONS
	<ul style="list-style-type: none"> <li>• Ensure that all protective sensors and automatic shutdowns are attached and functional.</li> <li>• Take extra care when using volatile flammables: fumes are more dangerous than liquids.</li> <li>• The heater's housing is made of TFE Teflon: avoid any chemicals that could attack this material.</li> <li>• <b>DO NOT</b> apply power to the heater without circulating fluid through it.</li> <li>• An over-temperature controller is required for installation. Please contact WK IMTEC Customer Service for specification.</li> <li>• There are no specific procedures for shutting-down the heater, except for maintaining pump flow. Ensure heater power is shut down while the fluid is still recirculating, then maintain recirculation for at least three minutes to ensure withdrawal of stored heat from the heater.</li> </ul>

WARNING	
	<p style="text-align: center;"><b>HAZARDOUS CHEMICALS CAN CAUSE SEVERE INJURY OR DEATH!</b></p> <p>Process chemicals may remain in the heater while attempting removal procedures if flushing and purging procedures are not followed. Before attempting removal procedures apply your company's personal protective equipment (PPE). PPE equipment must be applied in accordance with the instructions supplied by manufacturer of the PPE equipment.</p> <p>These procedures must be performed while wearing the appropriate personal protective equipment, such as, but not limited to:</p> <div style="display: flex; justify-content: space-around; align-items: center;"> <div style="text-align: center;">   <b>Goggles</b>                      Apron                 </div> <div style="text-align: center;">   <b>Gloves</b> </div> <div style="text-align: center;">   <b>Respirator</b>                      Boots                 </div> </div>

### 2.3.1 Chemical Safety Requirements

WARNING	
	<p style="text-align: center;"><b>DANGEROUS CHEMICALS MAY BE PRESENT!</b></p> <p>The In-Line Heater must be enclosed in a secondary containment area that will hold 110% of the fluid in the entire recirculation system including the process vessel. It is strongly advised that this enclosure be protected with interlocks to prevent operation if the enclosure is not properly sealed.</p> <div style="float: right; border: 1px solid black; padding: 5px;">  </div>

### 2.3.2 Environmental Specifications

Environmental Temperature	Indoor use only at 5°C to 40°C
Environmental Humidity	Maximum relative humidity is 80% for temperatures up to 31°C, decreasing linearly to 50% relative humidity at 40°C.
Altitude	Up to 2000 meters (6561.66 feet).
Supply Voltage	MAINS supply voltage fluctuations up to ±10% of the nominal voltage. Transient over voltages typically present on the MAINS supply.
Pollution	Applicable rated pollution degree 1

### 2.3.3 Power Modulator

This power modulator must be installed internal to an electrical enclosure.

### 2.3.4 Thermal Snap Switch Information

The snap switch is a self resetting thermostatic snap switch that is adhered to the end of the quartz tube on the outlet side and will interrupt the control signal. It is a critical safety device and must be utilized to prevent equipment damage in certain fault conditions.

The snap switch trips at 210°C. Typically if there is liquid flowing through the tube the switch does not trip. If for some reason, the tube is not full of liquid, or partially full, the quartz that is not in contact with liquid may continue to increase in temperature without being sensed by other devices. If the tube reaches 210°C, then the snap switch will open. It is the integrators responsibility to use this switch as part of their control circuit. It typically would be hard wired so that it would remove all power to the heater and require acknowledgement/reset before power could be re-applied.

The snap switch UL rating for 6000 cycles is 6A at 120VAC or 1.5 amps at 240VAC. Non UL rating of 5000 cycles for 30VDC/AC is 7 amps.

This concludes Section 2, *Safety Requirements*.



### 3 PRODUCT INSPECTION

This chapter describes guidelines to follow when unpacking and inspecting the WK IMTEC Accuheat Dual Tube In-Line Heater and standard optional equipment.

**NOTE**

These guidelines have also been included with the shipping manifest attached to the outside of the shipping container.

#### 3.1 Unpacking Considerations

**CAUTION**



**HANDLE WITH CARE!**

Quartz, like glass, is fragile and breaks on impact. Handle this equipment as any fragile quartz material. Protect the inlet and outlet tubes from impact at all times. Do not lift the heater by the nuts as these nuts are mounted directly on quartz fittings. Mishandling may result in non-warranty covered breakage (see below).



Do not lift the heater by the quartz fittings or by the interconnect manifolds.



Do not lift the heater by the quartz fittings or by the interconnect manifolds.

#### 3.2 Inspecting the Packaging

Before opening the shipping container, please look for evidence of transportation damage. It is your responsibility to notify the shipper promptly of any claims of freight damage. Please contact WK IMTEC also, so that we may be of assistance with an expeditious repair or replacement of the damaged parts.

CAUTION	
	<p style="text-align: center;"><b>POTENTIAL EQUIPMENT DAMAGE!</b></p> <p>Keep the WK IMTEC packaging and box in which the system and any options were shipped. If the system should ever need to be returned to WK IMTEC, it <b>must</b> be returned in an appropriate container to minimize risk of shipping damage. If the original container is not available, purchase a packing kit from WK IMTEC for a nominal fee.</p>

### 3.3 Checking the Contents

The Accuheat In-Line heater's shipping carton will contain the following items.

Quantity	Equipment
1	Accuheat In-Line heater (model specific)
1	Warranty Registration Card (in an envelope)

NOTE
If any of the above items are missing, contact WK IMTEC immediately.

If the system is shipped consolidated with other components, check your receiving documents and / or additional manuals for a checklist of the pertinent items.

This concludes Section 3, *Product Inspection*.

## 4 INSTALLATION PROCEDURES

### NOTE

The information provided in this section pertains to standard Accuheat models. Certain OEM specific models may have different plumbing and electrical connections in addition to other unique attributes. Where there are discrepancies between this document and your heater refer to the drawings and schematics that came with the heater.

This section includes the following topics:

- Emergency Off Recommendations
- Controller Recommendations
- Plumbing Recommendations
- Installation Procedures
- System Schematics

### 4.1 Emergency Off (EMO) Recommendations

The heater is installed as an internal device within the host equipment. The heater receives its electrical power from the host equipment. The host equipment must provide EMO devices to remove all power including removing power from the heater. This EMO device must be installed close to the equipment and within easy reach of the operator.

The host equipment must connect the over temperature and thermal snap switch to a Semi-compliant safety interlock circuit that will remove the power to the heaters if the maximum settings are exceeded for the thermocouple or if the thermal snap switch opens. Refer to Section 4.4, *Installation Procedures*, for power modulator wiring information.

### 4.2 Controller Recommendations

A controller is necessary for process temperature control and over-temperature protection. If you use a **non-WK IMTEC** controller, then that controller must drive a separate relay circuit for heater power. The relay circuit should have a primary and secondary relay in series for the line supply to the heaters, with a SSR or other sufficient high-cycle rated switching relay used as the primary, and a simple electromagnetic-closed secondary safety relay. The over-temperature controller should be capable of reaching and maintaining a 425°C setpoint.



### 4.3 Plumbing Recommendations

Dual Tube inline heaters use PFA manifolds that vary depending on the heater model. Please refer to the drawing that came with your heater to determine connection type. Never remove the manifolds and attempt to plumb directly to the quartz tubes as doing so may damage your heater and void the warranty. Damaged manifold replacements are available from WK IMTEC.

<b>WARNING</b>	
	<p style="text-align: center;"><b>DANGEROUS CHEMICALS MAY BE PRESENT!</b></p> <p>The In-Line Heater must be enclosed in a secondary containment area that will hold 110% of the fluid contained in the recirculation loop including the process vessel. It is strongly advised that this enclosure be protected with interlocks to prevent operation if the enclosure is not properly sealed.</p>

The standard manifold fittings are “pre-flared tube” and accommodate 3/4” OD Male flared connectors. All plumbing connections and fittings must be supported to eliminate any strain on the heater’s quartz plumbing connections. Recommended continuous operating pressure is no more than 40psi (275 kPa, 2.81 kg/cm<sup>2</sup>, 2.76 bar).

The heater is drained through the INLET tube (refer to Section 6, *Troubleshooting and Maintenance Procedures*). To facilitate draining and heater removal, install a manual or automatic drain valve on the INLET tube side. Never allow the quartz tube to become over pressurized. Read and understand the warning below.

<b>WARNING</b>		
	<p style="text-align: center;"><b>BURST HAZARD</b></p> <p>Never configure the recirculation loop with valves that could close on either side of the heater and prevent a release of pressure. If a reactive chemistry is allowed to be sealed inside an inline heater with no pressure relief, a burst of the quartz can occur.</p> <p>Do not exceed 60 PSI / 414 kPa operating pressure and 356° F / 180°C operating temperature.</p>	

The tubing between the heater and pump should have a “looped” run rather than a lateral run. Looped runs decrease pump vibrations from stressing the quartz stem (Figure 4-1).

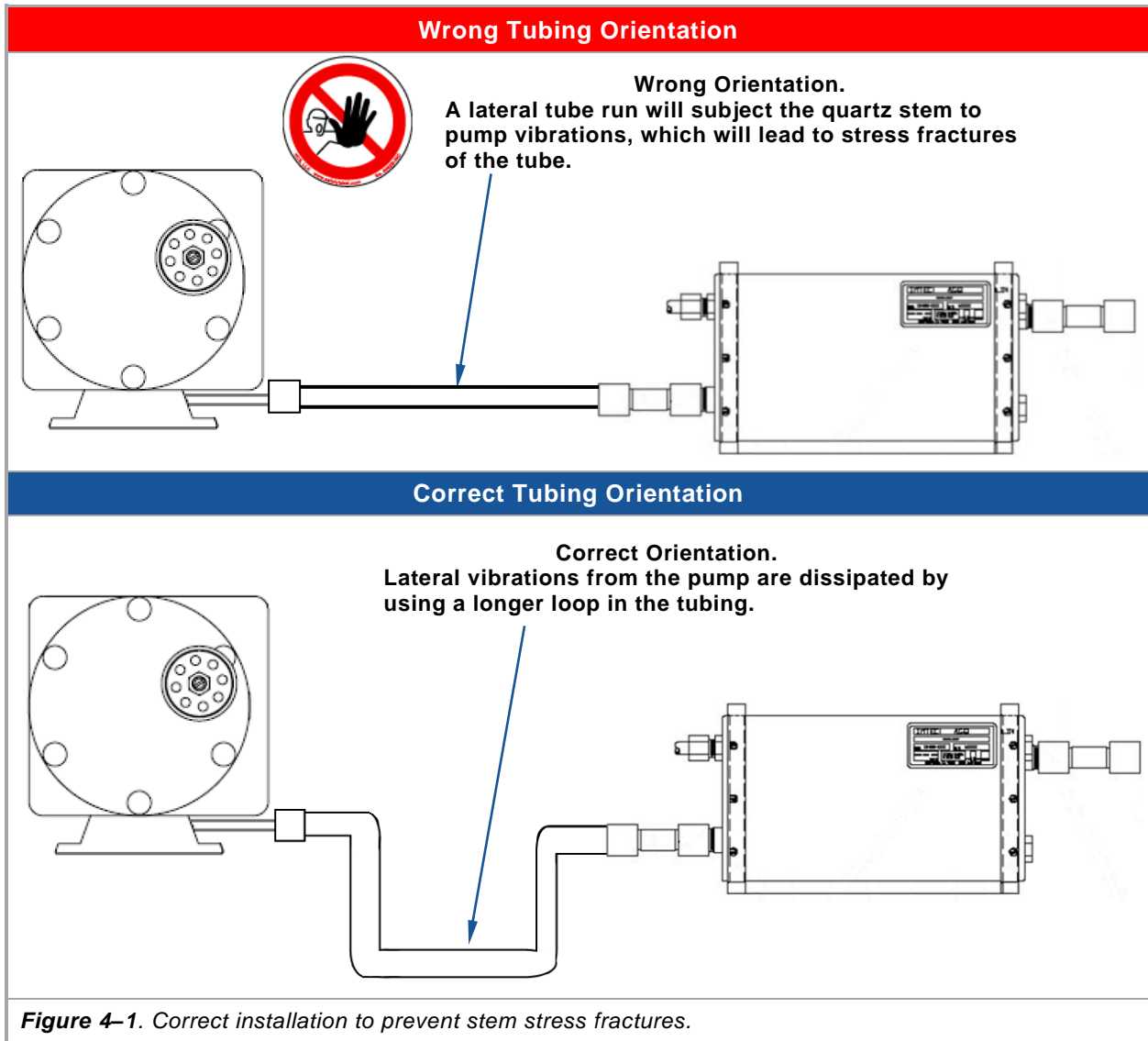

**Figure 4-1.** Correct installation to prevent stem stress fractures.

## 4.4 Installation Procedures

Installation instructions for all Dual Tube Accuheat models are divided into these parts:

- Installing the Power Modulator
- Installing the Heater
- Connecting the Power Modulator
- Connecting the Heater Power and Sensors
- Connecting the Heater Plumbing

### 4.4.1 Installing the Power Modulator

CAUTION	
	<p style="text-align: center;"><b>POTENTIAL PRODUCT OR EQUIPMENT DAMAGE!</b></p> <p>The <b>Power Modulator</b> must be electrically connected to the heater and used as part of the control circuitry, or the warranty is void! This device must be installed in an enclosure electrical compartment.</p>

Install the Power Modulator in a chemical-free environment such as an enclosed electronics compartment of the wetstation or a well-ventilated head case. This modulator can also be DIN Rail mounted using DIN 50022, 35 mm X 7.5 (1.38-inch X 0.30-inch).

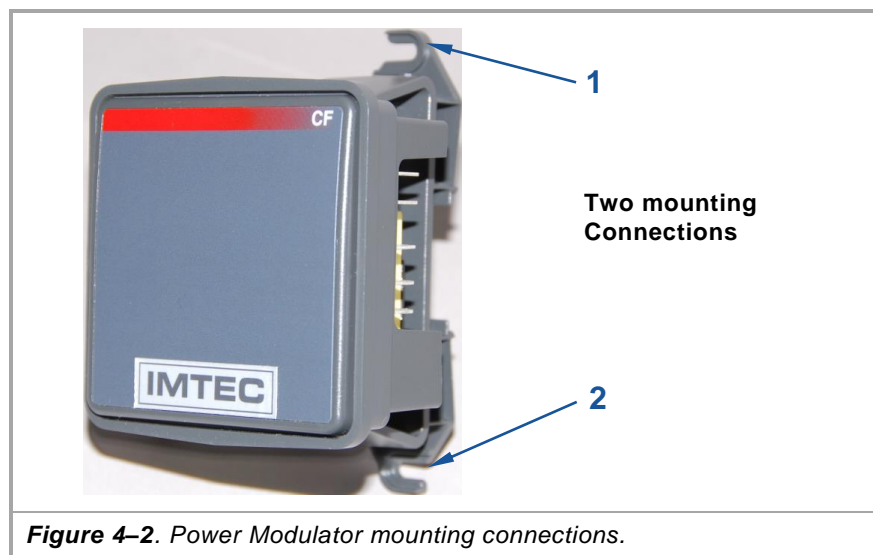

### 4.4.2 Installing the Accuheat In-Line Heater

There is no specified minimum or maximum distance from the bath, but the closer the heater’s OUTLET is positioned to the bath INLET, the more stable the recirculating system will be. Minimize the overall length of the plumbing loop and insulate the plumbing lines where possible to minimize heat loss.

Select a suitable location with a sturdy platform for mounting the heater (WK IMTEC recommends the heater be installed within the wetbench rear access chase). Some heaters can be mounted vertically or horizontally, while others can only be mounted horizontally. Make sure to check your specific model and follow the mounting instructions. Ensure all operating environment requirements are adhered to as stated in Section 1.4, *Specifications*, and Section 1.5, *Facilities Requirements*.

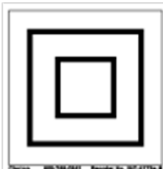
<b>WARNING</b>		
	<p><b>DANGEROUS CHEMICALS MAY BE PRESENT!</b></p> <p>The In-Line Heater must be enclosed in a secondary containment area that will hold 110% of the fluid contained in the entire recirculation loop including the process vessel. It is strongly advised that this enclosure be protected with interlocks to prevent operation if the enclosure is not properly sealed.</p>	

<b>CAUTION</b>	
	<p><b>POTENTIAL PRODUCT OR EQUIPMENT DAMAGE!</b></p> <p>A typical heater may be installed horizontally or vertically. If installing the heater in a vertical orientation, the “To Bath Exit” end must be oriented upwards. Please follow the instruction on the heater when installing vertically or warranty may be voided.</p>

#### 4.4.2.1 Horizontal Installation

- Using four (4) 1/4-20 screws, pre-drill (tapping as necessary) the mounting platform. Make sure that the horizontal installation label is facing up and the outlet fitting is in the 12-o’clock position (Figure 4-3). Mount the heater to the platform in a level position ( $\pm 1^\circ$  at both “x” and “y” axes).

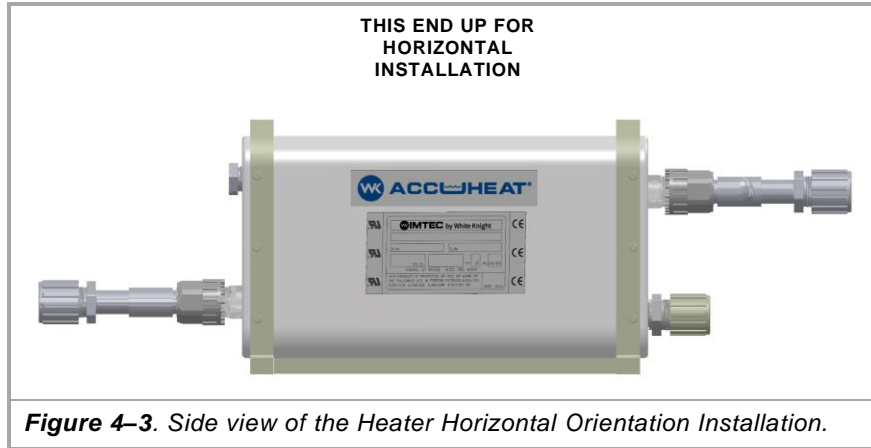

### CAUTION



#### POTENTIAL PRODUCT OR EQUIPMENT DAMAGE!

Do not install the heater without a minimum of a 5-inch air gap clearance on all sides — heat buildup and / or heater failure will result.

2. Ensure that the heater has at least a 5-inch (12cm) air gap clearance on all sides.
3. Connect power and plumbing as described in Sections 4.3.4 and 4.3.5.

#### 4.4.2.2 Vertical Installation

1. Using four (4) 1/4-20 screws, pre-drill (tapping as necessary) the mounting platform. Make sure that the Vertical installation label is facing up (Figure 4-4). Mount the Heater to the platform in a level position ( $\pm 1^\circ$  at both “x” and “y” axes).

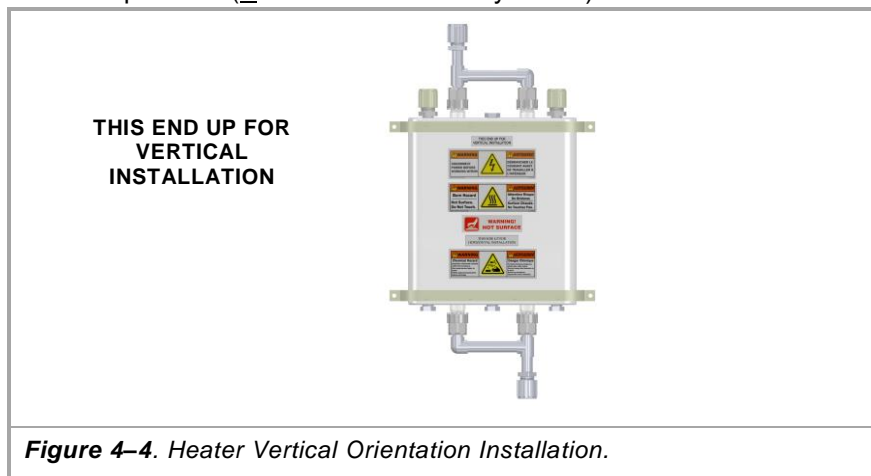



<b>CAUTION</b>	
	<p><b>POTENTIAL PRODUCT OR EQUIPMENT DAMAGE!</b></p> <p>Do not install the heater without a minimum of a 5-inch air gap clearance on all sides — heat buildup and / or heater failure will result.</p>

2. Ensure that the heater has at least a 5-inch (12cm) air gap clearance on all sides.
3. Connect power and plumbing as described in Sections 4.4.3 and 4.4.5

### 4.4.3 Connecting the Power Modulator

The Power Modulator is provided with 6.4 mm (0.25-inch) quick connect, push-on terminals. Refer to Table 4-1 below for power and connection descriptions.

**Table 4-1.** Power Modulator Output Specifications and Connections Descriptions.

<p><b>Modulator Power Input and Output Power Specifications</b></p>	<p><b>Input</b> is 24VAC <math>\pm</math> 10%, 50-60 Hz <math>\pm</math> 5%, 10 VA (watts) maximum power consumption.</p> <p><b>Output</b> is 8 amps at 240VAC or 30 VDC maximum resistive load or 250VA pilot duty, 120/240 VAC maximum inductive load.</p> <p>IMTEC part number 10-000-2366 for DIN Rail Mount – Spade Terminals, Type J-210 to 1038°C, Control Type-Heat (@375°C) 230-240VAC 50/60 Hz.</p> <p>IMTEC part number 10-000-2367 for DIN Rail Mount – Spade Terminals, Type J-210 to 1038°C, Control Type-Heat (@300°C) 230-240VAC 50/60 Hz.</p>
---	--

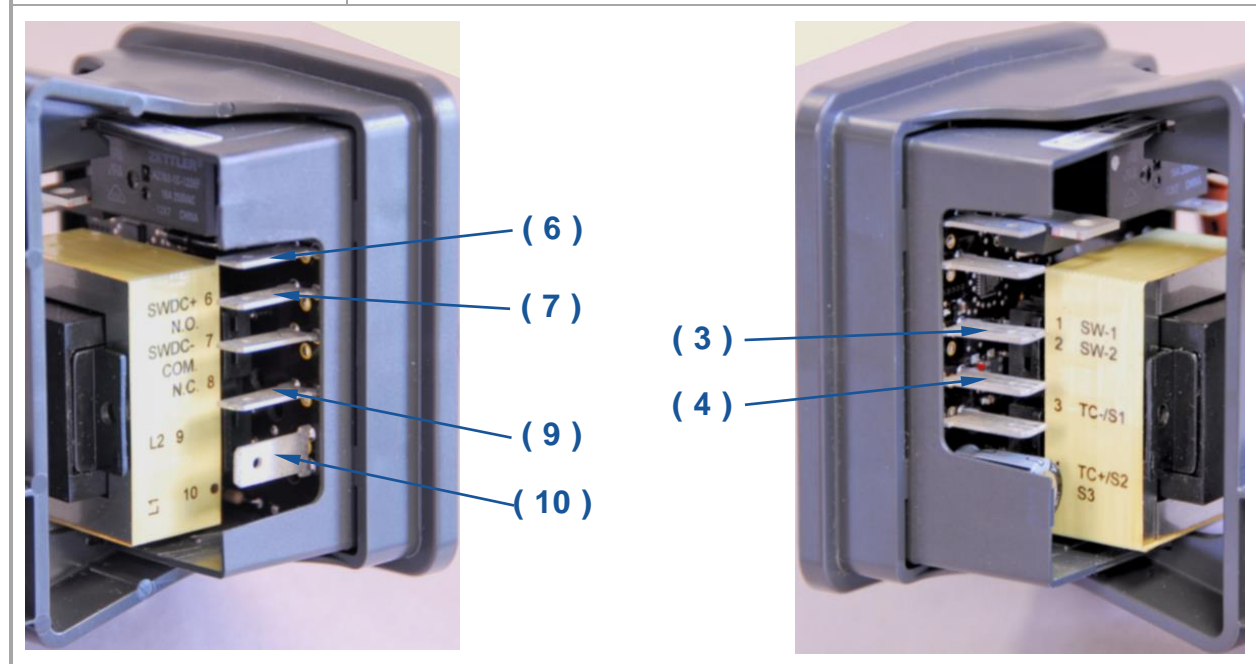

( 3 )	Position 3 – Thermocouple Negative (TC-)
( 4 )	Position 4 – Thermocouple Positive (TC+)
( 6 )	Position 6 – Relay Labeled NORMALLY OPEN. Note, NORMALLY CLOSED when is power on and less than 375 deg C <b>Wire in series with heater control signal so that when Power Modulator relay opens above 375 deg C, power to heater is interrupted</b> until temp reduces.
( 7 )	Position 7 –Relay common pole for the (6) connection discussed above
( 9 )	Position 9 – Primary Power (VAC Voltage In)
( 10 )	Position 10 – Primary Power (VAC Voltage In)

#### 4.4.4 Connecting the Heater Power and Sensors

<b>CAUTION</b>	
	<p style="text-align: center;"><b>POTENTIAL PRODUCT OR EQUIPMENT DAMAGE!</b></p> <p>An over temperature safety controller is required for installation. If your heater controller has a separate overtemperature input compatible with a J-type thermocouple, a second safety controller is not necessary. A J-Type thermocouple is provided and the recommended max set point is 425°C. When using Hot Phosphoric applications the required set point is 350°C</p>

Electrical schematics have been provided with this manual to serve as the most common standards for electrical and control connection recommendations. Select the appropriate standard for your configuration and wire the system as indicated in the schematics. If your configuration does not match one of these standards, please contact WK IMTEC Customer Service for assistance.

##### **Thermal Snap Switch Information:**

The snap switch is a self resetting thermostatic snap switch that is adhered to the end of the quartz tube on the outlet side and will interrupt the control signal. It is a critical safety device and must be utilized to prevent equipment damage in certain fault conditions.

The snap switch trips at 210°C. Typically if there is liquid flowing through the tube the switch does not trip. If for some reason, the tube is not full of liquid, or partially full, the quartz that is not in contact with liquid may continue to increase in temperature without being sensed by other devices. If the tube reaches 210°C, then the snap switch will open. It is the integrators responsibility to use this switch as part of their control circuit. It typically would be hard wired so that it would remove all power to the heater and require acknowledgement/reset before power could be re-applied.

The snap switch UL rating for 6000 cycles is 6A at 120VAC or 1.5 amps at 240VAC. Non UL rating of 5000 cycles for 30VDC/AC is 7 amps.

### 4.4.5 Connecting the Heater Plumbing



Accuheat Dual-tube models require only two plumbing connections. It is important to follow the guidelines below.

<b>CAUTION</b>	
	<p style="text-align: center;"><b>POTENTIAL PRODUCT OR EQUIPMENT DAMAGE!</b></p> <p>When planning the plumbing route, it is important that the flow from the pump through the succeeding circuit components be in a continuing upward angle so that no downward element can serve as a vapor trap. This is most critical in the plumbing circuit from the heater OUTLET port to the bath. Failure to correctly plumb the heater will void the warranty!</p>

**For Accuheat models with a parallel flow path:**

1. On models with Parallel flow paths, connections are made to the PFA manifolds at either end of the heater. The manifolds terminate in a flared tube with pre-installed nut.
2. Identify the size and type of nut on the inlet and outlet manifolds for your specific heater. Prepare your plumbing using the appropriate male connector.
3. Attach and tighten the nut of the manifold per the recommendations of the nut manufacturer.

**AHQD Standard Manifolds for parallel flow:**

<b>AHQD Manifolds</b>			
<i>Manifolds sold separately. Inlet and outlet manifolds sold individually.</i>			
Part	Type	kW	Fitting
10-003-0623	 F-Manifold	6.0	3/4-in Male Flare, PFA Nut
10-003-0619			3/4-in Nexus / Pillar S300
10-003-0627		9 - 24	3/4-in Male Flare, PFA Nut
10-003-0620			3/4-in Nexus / Pillar S300
10-003-0618	 H-Manifold	6.0	3/4-in Male Flare, PFA Nut
10-003-0624			3/4-in Nexus / Pillar S300
10-003-0625		9 - 24	3/4-in Male Flare, PFA Nut
10-003-0626			3/4-in Nexus / Pillar S300

#### 4.4.5.1 Installing the Fit-One plumbing nuts.

The Fit-One nuts need to be torqued to provide maximum security against leaks. Any 1/4" drive torque wrench with a range of at least 0-50 in.lbs. may be used. These are readily available online and in hardware stores.

#### 4. Determining the proper torque value.

The torque wrench must be adjusted based on its pivot length. The correct torque spec for the WK IMTEC FIT-ONE nut is 28 in•lb. But, because torque wrenches come in different lengths, the proper setting for the torque wrench must be calculated based on the formula below to work properly with the WK IMTEC torque wrench adapter and achieve the desired 28 in•lb.

Measure the distance from the center of the 1/4" drive attachment to the middle of the handle grip. The handle grip is typically knurled. For most accurate torque calculations, measure to the middle point of the grip (referred to as the "1/2 grip length"). This is dimension "A".

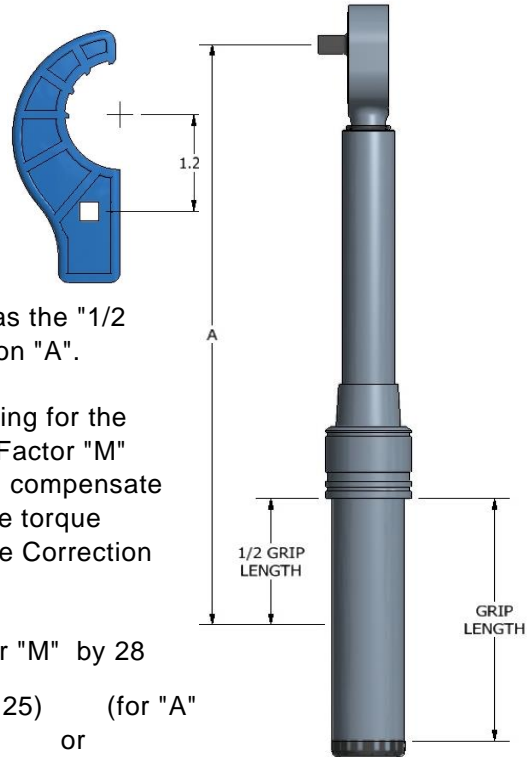

To determine the correct setting for the torque wrench, a Correction Factor "M" must be calculated which will compensate for the additional length of the torque wrench adapter. Calculate the Correction Factor "M" as follows:

Multiply the Correction Factor "M" by 28

$$M = A / (A + 1.25) \quad (\text{for "A"}$$

$$\text{or}$$

$$M = A / (A + 31.75) \quad (\text{for "A" ... ..,})$$

lb•in to determine the correct setting for your specific torque wrench:  
Torque Wrench Setting = (28 in•lb) \* M

Using WK IMTEC's Torque Wrench Adapter to Install Imtec FIT-ONE Nuts

With the proper torque setting on your torque wrench, the torque wrench adapter (**P/N:10-004-7007**) may now be used. Slide the square cutout in the adapter onto the torque wrench. Make sure the torque wrench adapter remains parallel to the torque wrench handle.

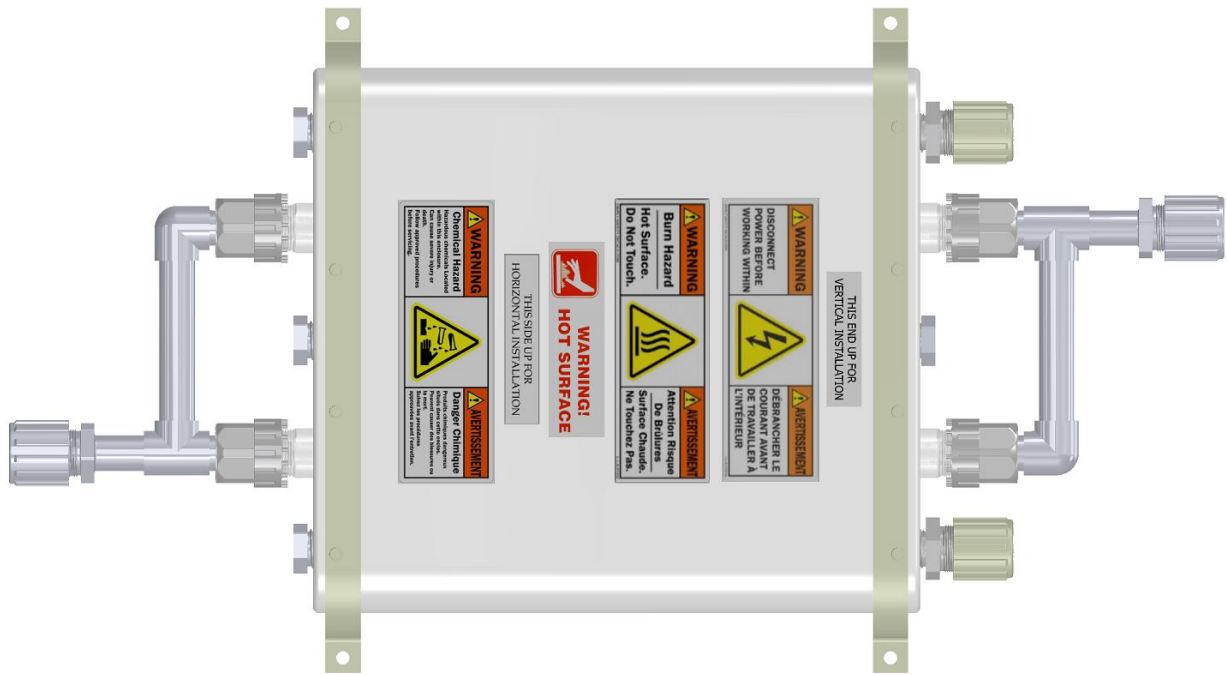

**Figure 4-5.** Heater Recommended Orientation Installation for H-Manifold, PN 10-003-0625 shown

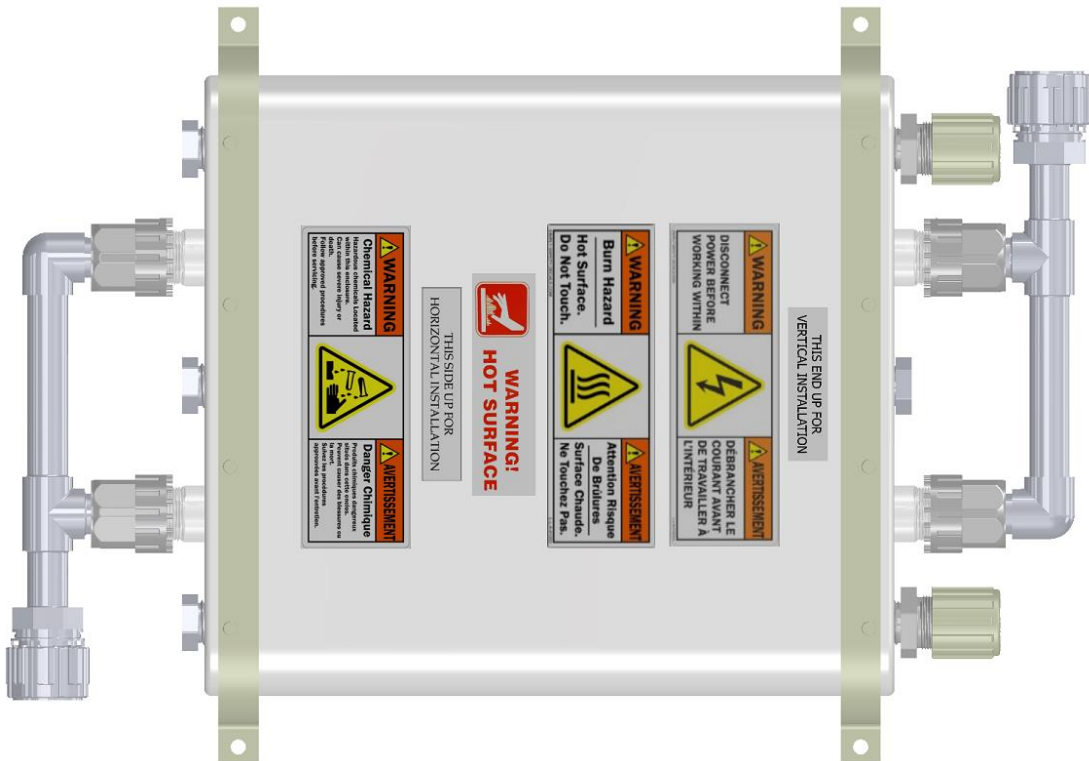

**Figure 4-6.** Heater Recommended Orientation Installation for F-Manifold, PN 10-003-0620 shown

This concludes Section 4, *Installation Procedures*.

## 5 OPERATING INSTRUCTIONS

This section describes the operation of a typical Accuheat Dual Tube In-Line Heater. The information includes:

- Safety Precautions
- Controls and Indicators
- Ramp-Up
- Shut-down



### 5.1 Safety Precautions

As stated in Section 2, *Safety*, and re-stated here for your safety:

CAUTION	
	<p><b>HOT SURFACES!</b></p> <p>Surfaces may be as hot as 200°C. Do not move the heater or touch the hot surfaces of the heater.</p>

The following warning labels are placed on the equipment. Adhere to these safety labels. Do not exceed the label's recommend operating pressures or temperatures.



⚠ WARNING	
	
<p><b>Burst hazard.</b> Do NOT exceed 60 PSI/414 kPa operating pressure and 356°F/180°C operating temperature.</p>	





<b>! WARNING</b>		<b>! AVERTISSEMENT</b>
<p><b>Chemical Hazard</b>                  Hazardous chemicals Located within this enclosure.                  Can cause severe injury or death.                  Follow approved procedures before servicing.</p>		<p><b>Danger Chimique</b>                  Produits chimiques dangereux situés dans cette enclos.                  Peuvent causer des blessures ou la mort.                  Suivez les procédures approuvées avant l'entretien.</p>

<b>! WARNING</b>		<b>! AVERTISSEMENT</b>
<p><b>Burn Hazard</b>                  Hot Surface.                  Do Not Touch.</p>		<p><b>Attention Risque De Brûlures</b>                  Surface Chaude.                  Ne Touchez Pas.</p>

<b>! WARNING</b>		<b>! AVERTISSEMENT</b>
<p><b>DISCONNECT POWER BEFORE WORKING WITHIN</b></p>		<p><b>DÉBRANCHER LE COURANT AVANT DE TRAVAILLER À L'INTÉRIEUR</b></p>

<b>WARNING</b>		
	<p style="text-align: center;"><b>DANGEROUS CHEMICALS MAY BE PRESENT!</b></p> <p>The In-Line Heater must be enclosed in a secondary containment area that will hold 110% of the fluid the heater in the entire recirculation loop including the process vessel. It is strongly advised that this enclosure be protected with interlocks to prevent operation if the enclosure is not properly sealed.</p>	

Read, understand, follow and implement the following general warnings and cautions during the use of this heater.

GENERAL WARNINGS	GENERAL CAUTIONS
	<ul style="list-style-type: none"> <li>• Ensure that all protective sensors and automatic shutdowns are attached and functional.</li> <li>• Take extra care when using volatile flammables: fumes are more dangerous than liquids.</li> <li>• The heater's housing is made of TFE Teflon: avoid any chemicals that could attack this material.</li> <li>• <b>DO NOT</b> apply power to the heater without fluid circulating through it.</li> <li>• An over-temperature safety controller is required for installation. Please contact WK IMTEC Customer Service for specification.</li> <li>• There are no specific procedures for shutting-down the heater, except for maintaining pump flow. Ensure that the heater power is shut down while the fluid is still recirculating. Then maintain recirculation for at least three minutes to ensure withdrawal of stored heat from the heater.</li> </ul>

### 5.2 Controls and Indicators

The standard heater has no indicators or user controls. External controllers must be used with this equipment. Refer to the operating instructions of the external controller used with this application.

### 5.3 Ramp-Up

Ensure that the fluid pump is turned on before powering up the heater. Ideally, the INLET pressure at the heater should not exceed 40 PSI (275 kPa, 2.81 kg/cm<sup>2</sup>, 2.76 bar). The absolute maximum is 60 PSI as stated on the product's warning label.



**⚠ WARNING**



**Burst hazard.** Do NOT exceed 60 PSI/414 kPa operating pressure and 356°F/180°C operating temperature.

**CAUTION**

	<p style="text-align: center;"><b>POTENTIAL PRODUCT OR EQUIPMENT DAMAGE!</b></p> <p>Do not power-up the heater unless there is fluid circulating through it.</p>
---	--



## 5.4 Shut-Down

There are no specific procedures for shutting-down the heater, except for maintaining pump flow.

Ensure that the heater power is shut down while the fluid is still recirculating, then maintain recirculation for at least three minutes to ensure withdrawal of stored heat from the heater.

This concludes Section 5, *Operating Instructions*.

## 6 TROUBLESHOOTING and MAINTENANCE PROCEDURES

### 6.1 Troubleshooting Procedures

Most problems related to heating involve a “non”-WK IMTEC supplied control system and interlock systems that are used in conjunction with the heater. Most troubleshooting is performed to determine if the heater has failed or whether the symptoms are related to an external system. The heater has no user serviceable parts inside and should never be opened for any reason.

The following table lists common symptoms, probable causes, and corrective actions.

Symptom	Possible Cause	Check	Corrective Action
<b>Heater does not heat</b>	No Power to the heater	When the control system is calling for heat, check for voltage to all heater elements. This should be checked at the end of the heaters power cable to eliminate all other connections and interlocks.	If no voltage is present, refer to the control system schematic provided by the tool maker for troubleshooting information.  If there is voltage at the heater wires, measure heater resistance as noted below.
	Heater Element Failure	Disconnect the heater power wires from the control system and measure the resistance of the heater element(s) to see that they are within +/-10% of the specification. Refer to model specific information for specs.	If the resistance is in spec, the heater elements are good.  If they are out of spec, the unit should be returned to WK Imtec for repair. In most cases, the heaters can be rebuilt.
<b>Heater Snap Switch is open</b>	Air trapped in heater	Ensure that heater is mounted so that air cannot be trapped inside. Refer to Section 4, <i>Installation Procedures</i> .	Correct the mounting per the installation section and measure resistance of the heater elements to ensure they were not damaged. Once the heater has cooled the snap switch should reset.
	Defective Snap Switch	When the heater has been deenergized for at least 15 minutes, measure for continuity across the snap switch leads.	If the tube is not being heated and the snap switch reads open, it is defective. The heater should be returned to WK Imtec for repair.
<b>LD-1 Leak Detect Alarm</b>	Internal Leak	Refer to your model schematic and measure the 100kΩ terminating resistor's resistance of the leak detect wiring.	If the resistance is greater than 60kΩ and less than 120kΩ it should not trigger the leak detect module. Refer to the LD-1 Manual for troubleshooting.

Symptom	Possible Cause	Check	Corrective Action
<b>Visible liquid coming from heater housing</b>	Internal Leak	Certain chemistries will etch quartz and over time create pinhole leaks that may not cause an immediate fault.	Immediately shut down the heater and return to WK Imtec for evaluation.
<b>Overtemp circuit has tripped</b>	Improper Overtemp setpoint	Check to see that the Overtemp setpoint is a minimum of 25°C above the setpoint of the power modulator setpoint.	Raise the Overtemp setpoint accordingly.
	Defective Overtemp controller	This item is not supplied by WK Imtec. Refer to the documentation supplied with your tool for troubleshooting.	Repair or replace as necessary.
	One J-type thermocouple is defective	Connect both thermocouple leads to a thermocouple meter. With a cool heater both thermocouples should read within a few degrees of each other.	If either thermocouple is defective, the heater must be returned to WK Imtec.
	Power modulator is faulty	If both thermocouples check ok, the power modulator may be defective. Connect a J-type thermocouple simulator up to the power modulator and set for 10°C above it's setpoint. This should cause the interlock relay contacts to open.	If the contacts do not open the power modulator is defective and should be replaced. Contact WK Imtec for a replacement.

This ends the Troubleshooting Procedures. If the heater needs to be returned to WK IMTEC for servicing go to Section 6.3, *Removing the Heater*.

## 6.2 Maintenance Procedures

**Monthly:** Check to ensure that all plumbing connections at the INLET and OUTLET are tight.

### NOTE

There are no other maintenance procedures nor are there any periodic maintenance (PM) procedures necessary. The following information readies the heater for returning it to the WK IMTEC factory for repair.

## 6.3 Removing the Heater

### WARNING



#### DANGEROUS VOLTAGE IS PRESENT!

Hazardous voltages exist. Use caution around exposed circuits. Check area for exposed contacts prior to contacting this equipment. To ensure operator, equipment, and product safety, use care when operating this equipment. The following warnings must be adhered to.

- The Accuheat comes with safety devices. For your safety and to ensure the Accuheat works as designed, do not disconnect or modify them. Report any malfunctions to WK IMTEC Customer Service.
- The heater's housing is made of TFE Teflon: avoid any chemicals that could attack this material.

### WARNING



#### HAZARDOUS CHEMICALS CAN CAUSE SEVERE INJURY OR DEATH!

Process chemicals may remain in the heater while attempting removal procedures if flushing and purging procedures are not followed. Before attempting removal procedures apply your company's personal protective equipment. These procedures must be performed while wearing the appropriate personal protective equipment, such as, but not limited to:



Goggles



Gloves



Respirator

Apron

Boots

### CAUTION



#### POTENTIAL PRODUCT OR EQUIPMENT DAMAGE!

A heater that has suffered an electrical failure may be returned to WK IMTEC for economical repair. However, breakage of the quartz will significantly increase repair costs and may result in the heater not being able to be repaired. Be particularly careful of the quartz flared INLETS and OUTLETS; carefully re-mount the knurled Teflon nuts to protect these quartz items.

1. Ensure all electrical power has been turned off to the heater
2. Purge, flush, and drain the entire recirculation loop and refill with DI H<sub>2</sub>O. Recirculate for 10 minutes and then drain the system. Repeat until chemical is satisfactorily diluted.
3. The heater will drain from the INLET tube. Open the manual or automatic drain valve installed on the INLET side, making sure that adequate drainage is available to receive the fluid.
4. Lock out and Tag out the electrical supply and then disconnect the heater wiring from any control systems.
5. Disconnect the OUTLET line and allow the fluid to siphon until empty (typically 20-30 ml of water will remain after siphoning).
6. Carefully re-mount the knurled Teflon nuts to protect the quartz INLETS and OUTLETS.
7. Flush the housing externally with DI water.
8. Remove any hold-down hardware.
9. Remove the heater.

**NOTE**

When returning the heater for repair, drain, dry, and repackage it as described in Section 6.4, *Return Authorization Procedures*.

## 6.4 Return Authorization Procedures

The following policies and procedures are for returning a heater for repair to the WK IMTEC factory

- Return Policies
- Obtaining a Return Authorization
- Packing the heater for return

### 6.4.1 Return Policies

1. All heaters should be returned in WK IMTEC shipping containers. If the original container is no longer available, a shipping container can be purchased for a nominal fee from WK IMTEC Customer Service.
2. All returned heaters must be authorized by a WK IMTEC representative. If a heater is shipped to WK IMTEC without a Return Merchandise Authorization (RMA) number, the heater will be refused by the WK IMTEC Receiving Department and returned to the sender.
3. All freight charges are the responsibility of the shipper. Insure for full or repaired value.

### 6.4.2 Obtaining a Return Authorization Number

1. Please have the following information ready:
  - Serial number of the heater
  - Reason for the repair
  - Type of chemistry used with the heater
  - Process temperature used
  - Repair Purchase Order Number (used for tracking; there can be no charge amount until the heater has been evaluated by WK IMTEC).
2. Call WK IMTEC Acculine Customer Service at (435) 783-6040 and request an RMA number.
3. If needed, order a shipping container kit and / or approved plastic bags. If the heater is contaminated with process chemistry (**not** DI water), ask for a contamination shipping kit.

#### NOTE

Always follow your company's procedures for handling and shipping of chemically contaminated material. Follow any applicable local, state, and Federal laws in regards to shipping chemically contaminated materials.

4. For contaminated heaters, cut the power cable leaving two (2) inches from the housing nut.

### 6.4.3 Packing Heater for Return or Decommissioning

1. Have the heater shipping container ready.
2. Ensure that heater housing has been neutralized of all chemicals. Test with pH paper.
3. Provide a description of the chemistry and process temperature used with the heater.
4. Disconnect the electrical connections and plumbing and tape the power cable to the outside.
5. Flush the heater internally and externally with DI water. Drain the heater until no free moisture is present.
6. Repeat step 5 until chemistries are neutralized. Test with pH paper.
7. Insert the heater into an approved plastic bag. Three (3) are supplied with the shipping kit. Additional bags may be obtained from WK IMTEC Customer Service.
8. If it was necessary to remove any of the PFA manifolds from the heater, make sure they are also bagged and packed in such a way as to not damage the heater.

9. Carefully and completely squeeze out all of the trapped air. Seal the bag with a tie-wrap.
10. Repeat steps 8 and 9 twice more, using the remaining two bags.
11. Carefully place the bagged heater into the lower molded foam section in the shipping container.
12. Place upper molded foam section in place over the heater.
13. Pull up the bag liner, twist its top once and squeeze out all trapped air. It is important that all trapped air be removed. Twist the liner excess to seal out the air and use a tie-wrap to secure the liner top. This ends the decommissioning steps.
14. Insert any photos, diagrams and documentation of chemicals and process temperature into a sealable plastic bag and place on top of box liner.
15. Seal the bath's shipping container with packing tape. Do not staple the container closed.
16. Remove the backing and secure a shock watch and companion label to the side of the container.
17. Write or apply the following labels on all sides of container (except bottom). These labels are: "**GLASS**" and "**FRAGILE**".
18. Mark the RMA number legibly on the sides of the container.
19. Ship the container to WK IMTEC.

If you have any questions about WK IMTEC's return authorization policies or procedures, please contact WK IMTEC at:

<b>WK IMTEC Acculine</b> 187 East 670 South Kamas, UT 84036	Phone: (435) 783-6040 Fax: (435) 783-6128
Email: <a href="mailto:customer.support@wkfluidhandling.com">customer.support@wkfluidhandling.com</a>	From 8:00 a.m. to 5:00 p.m., MST, Monday through Friday

This concludes Section 6, *Troubleshooting and Maintenance Procedures*.

