

# ***PSD24 Owner's Manual***

---



Page left intentionally blank

# Table of Contents

---

1 Introduction.....	1
2 Specifications & Performance .....	2
2.1 Pump Specifications .....	2
2.2 PSD24 Performance Curves .....	3
2.4 PSD24 Exploded View Drawing.....	4
2.3 PSD24 Dimensional Drawing.....	6
3 Installation .....	7
3.1 Installation Precautions .....	7
3.2 PSD Installation Advantages.....	8
3.3 System and Pump Environment.....	8
3.4 Control and Monitoring Connections .....	9
3.5 PSD 24 Installation Instructions .....	10
4 Pump Service & Rebuilds.....	11
4.1 PSD Ordering instructions.....	11
4.2 Rebuild Kit Ordering Instructions .....	12
4.3 Tools.....	14
4.4 Torque Instructions.....	14
4.5 Disassembly instructions.....	15
4.6 Assembly Instructions .....	16
5 Accessories .....	17
6 Warranty .....	18
7 Certification & Declaration of Conformity .....	19
White Knight Support .....	20

Manual content and data are subject to change without notification.

Manuals available online at: [wkfluidhandling.com/owners-manuals](http://wkfluidhandling.com/owners-manuals)

Page left intentionally blank

## 1 Introduction

Dear valued customer,

Thank you for purchasing White Knight products.

Our dedicated team designs products to meet your exacting specifications with the highest commitment to quality.

White Knight provides the highest quality fluid handling products through controlled, consistent in-house engineering and manufacturing. Our safe, reliable products offer superior performance, optimized efficiency, and simplified maintenance. And, we continue to lead the industry with new technologies and products.

Our patented designs offer a variety of size and material options to meet stringent requirements of high-pressure chemical delivery systems; high-temperature re-circulation processes; chemical reclaim and bulk transport applications; as well as slurry systems.

White Knight has received many prestigious awards for innovation and manufacturing programs. We rigorously manage our quality assurance processes to ensure consistency and reliability. Our quality controls include strict cleanliness procedures and consistent manufacturing processes. For example, product assembly and testing is done in a temperature and humidity-controlled cleanroom.

Please peruse this manual before installing your White Knight product. It details installation requirements and setup instructions, and provides additional information and accessories to enhance the product's functionality.

Our team has gone to great lengths to ensure our products serve your needs and meet your requirements.

Further, we provide the highest quality products at the best value, and we back them up with excellent warranties and world class support.

Sincerely,

White Knight Fluid Handling

## 2 Specifications & Performance

### 2.1 Pump Specifications

PSD24 Pump Performance Specification <sup>1</sup>								
Flow Rate	Theoretical Displacement Per Cycle	Suction Lift Wet	Suction Lift Dry	Sound Pressure <sup>3</sup> dB(a)	Sound Power <sup>3</sup> dB(a)	Max. Size of Passible Solids <sup>4</sup>	Max Operating Temperature	Air Supply Pressure Limits <sup>5</sup>
372 lpm (98.3 gpm)	1.64 L (0.433 gal)	9.5 L (31.2 ft <sup>2</sup> )	5 m (16 ft)	84.2 89.8	83.2 91.1	8 mm (0.32 in)	100°C	30 psi (100 psi)

All tests performed with water at ambient temperatures and PTFE check balls

1. Pump Specifications are subject to change based on configuration ordered
2. Suction lift diminishes with wear of pump, minimize suction lift to maximize performance
3. dB Level at 100 psi 50CPM (top) and 100 psi maximum CPM (bottom).
4. The passing of solids may shorten the life of a pump
5. Minimum startup pressure (Max supply pressure)

#### STORAGE

PSD pumps that are not put into operation upon delivery must be stored in an environment where they are protected from moisture, extreme temperatures, UV radiation, vibration, and should be kept clean. White Knight recommends an environment of ambient temperature (between 60° F (15°C) and 80°F (25°C)) with a humidity level below 65%.

#### Maintenance and Torque Values

Upon installation of the pump, as well as after a few hours of operating the pump, the head and manifold bolts must be re-torqued. Tie bolts and manifold bolts must be re-torqued to values specified in the table below. Re-torqueing will be required after the pump has set for extended periods of time, run in thermal cycling applications, been dismantled, or when there is a large difference between environmental and fluid temperatures. See torqueing instructions on page 14.

	Assembly Torque in-lbs. (kg-cm)
Tie Bolts	75 (86.4)
Manifold Bolts	60 (69.1)

2.2 PSD24 Performance Curves

**PSD24 Performance Curves**

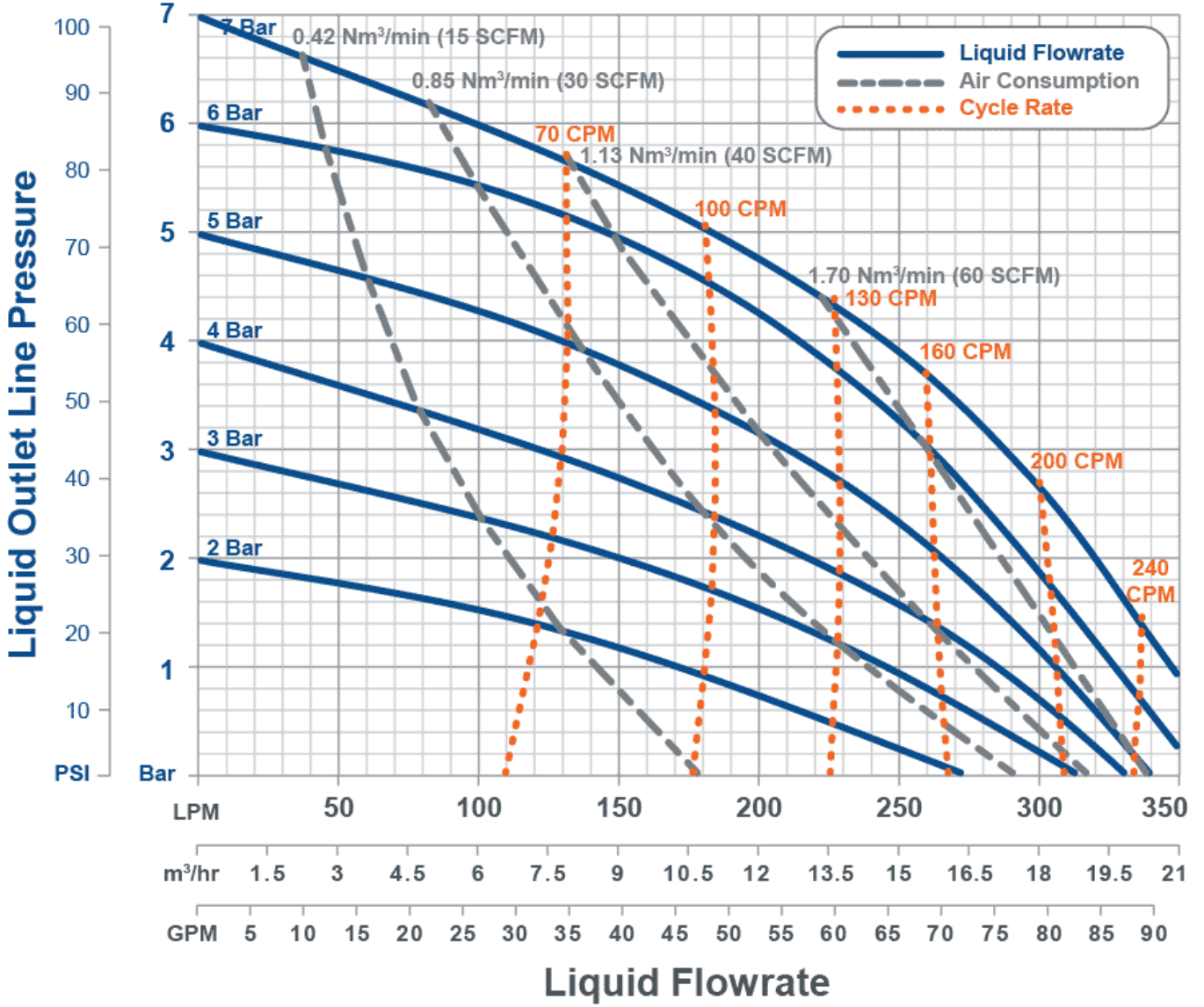

## 2.4 PSD24 Exploded View Drawing

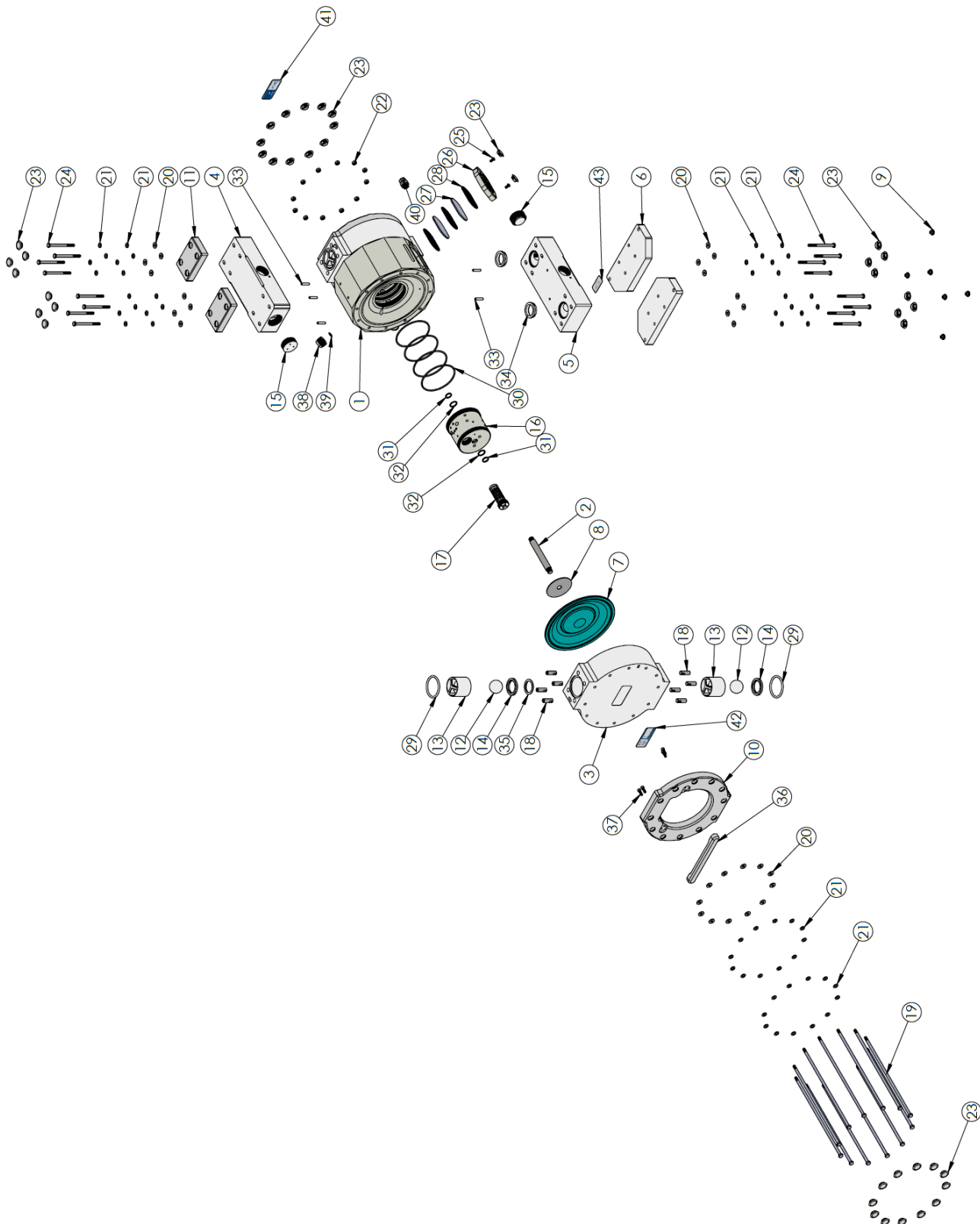



ITEM NO.	PART NUMBER	DESCRIPTION	QTY.
1	1125-NP-0004	BODY	1
2	5144-SS-0003	SHAFT	1
3	2127-TE-0063	HEAD, PTFE	2
4_N	7500-TE-0011	OUTLET MANIFOLD, PTFE, NPT	1
4_X	7500-TE-0049	OUTLET MANIFOLD, PTFE, BUTTRESS	1
5_N	7500-TE-0009	INLET MANIFOLD, PTFE, NPT	1
5_X	7500-TE-0048	INLET MANIFOLD, PTFE, BUTTRESS	1
6	1146-PV-0003	BASE PLATE	2
7	3200-TE-0003	DIAPHRAGM, PTFE	2
8	3300-SS-0005	STRIKE PLATE	2
9	10040-NB-0001	FEET RUBBER	6
10	2129-PV-0005	HEAD RETAINER	2
11	2129-PV-0006	MANIFOLD RETAINER	2
12	4100-TE-0006	1.6875" CHECK BALL, PTFE	4
13	4137-TE-0006	CHECK CAGE, PTFE	4
14	10050-MP-0003	D-RING, MODIFIED PTFE	4
15	10040-TE-0017	1.5" NPT PLUG	2
16	6600-NP-0003	AIR MOTOR	1
17	14850-PT-0005	SPOOL/ SLEEVE ASSEMBLY	2
18	10011-SS-0003	MANIFOLD NUT	16
19	10010-SS-0108	TIE HEX BOLT	12
20	10050-SS-0006	WASHER	40
21	10050-SS-0007	WASHER, BELLEVILLE	80
22	10010-SS-0020	HEX NUT 8M	12
23	10040-PE-0007	PLUG, CAP	44
24	10010-SS-0021	HEX CAP SCREW, M8 x 1.0 x 80	16
25	10010-SS-0010	SCREW	4
26	6150-NP-0010	MUFFLER CAP	2
27	6140-FP-0007	FELT MUFFLER	4
28	6140-PP-0006	MUFFLER SPACER	6
29	10080-TE-333	333 O-RING	4
30	10080-EM-246-70	-246 O-RING	4
31	10050-UH-0007	GLIDE SEAL	2
32	10080-EM-117-70	-117 O-RING	2
33	10020-WC-0002	GUIDE PIN, n.25, 1.25	6
34	4135-TE-0019	BOTTOM MANIFOLD WEAR SEAT, PTFE	2
35	4135-TE-0017	WEARABLE SEAT, PTFE	2
36	10200-PV-0001	STRAP ANCHOR	2
37	10010-SS-0033	1/4-20 SOCKET HEAD CAP SCREW, .750	8
38	6060-NP-0009	INLET ADAPTER, 1/2" NPT	1
39	10080-EM-014-70	014 O-RING	1
40	12100-PV-0030	SLEEVE WRENCH	1
41	19100-PP-0056	PSD24 LABEL	1
42	19100-PP-0058	LABEL, CE STICKER	1
43	19100-PP-0124	PATENT STICKER	1

2.3 PSD24 Dimensional Drawing

**PSD24**

MAIN DIMENSIONS ARE IN INCHES  
 [BRACKETED] DIMENSIONS ARE mm

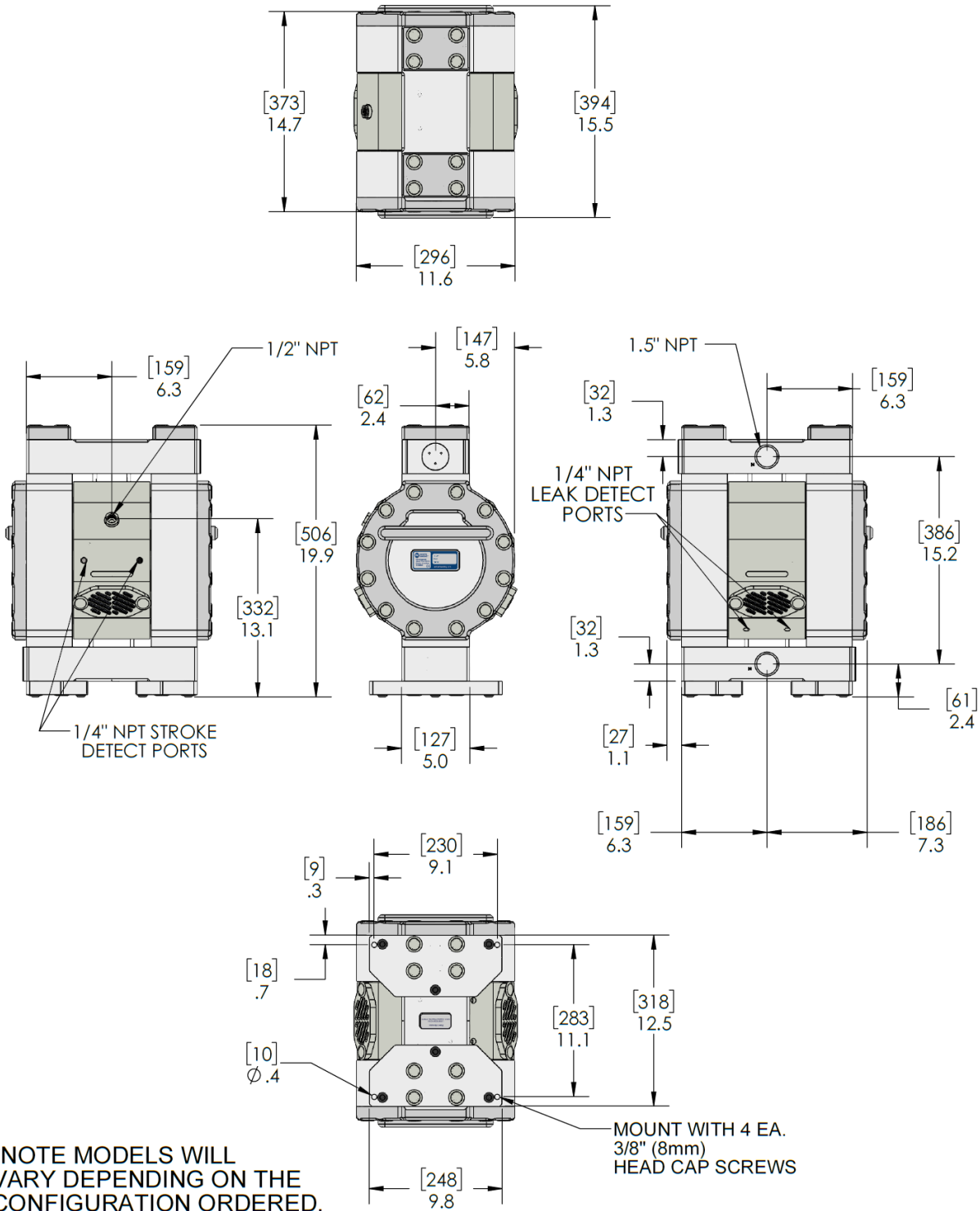

\*NOTE MODELS WILL VARY DEPENDING ON THE CONFIGURATION ORDERED.

## 3 Installation

### 3.1 Installation Precautions

<b>Required Air Flow and Operating Pressure</b>
Required Air Flow for the PSD24 is 3/8" minimum orifice unrestricted at 2 meters lengths or lower, larger lengths may require a larger diameter for full flow. An adaptor is included for 1/2" NPT with all pumps. Max air supply for the PSD24 is 7 Bar (100 PSI).
<b>Restriction of Liquid Inlet Line</b>
Restricting the liquid supply of the pump forces the pump to work harder than normal and should be avoided whenever possible, especially when pumping viscous liquids. Attempting to operate the pump against a closed liquid inlet will cause serious damage to the pump, and will void the warranty. If you wish to slow or stop your pump this may be done by closing off the liquid outlet.
<b>Supply Pressure Recommendations</b>
The life of your pump may be extended significantly by operating your pump 30%-40% below redline operating supply pressures. The use of undersized regulators, valves, and supply lines can decrease pump performance and longevity significantly.
<b>Orientation</b>
White Knight does not recommend installing your pump in any position other than its upright position. Check valves within White Knight PSD pumps are actuated by gravity and/or flow and perform optimally in the upright position.
<b>Failure Potential</b>
It is possible that the diaphragm may fail. In such a situation it is possible that chemical could enter the air side of the pump, and may even escape through the muffler. In such a situation the muffler media must be replaced and the air side purged. White Knight recommends that the implementation of a one way valve on the air side to protect air lines from contamination in the event of a diaphragm failure.
<b>Muffler</b>
Pump performance may be restricted in the event of a clogged muffler. Regular inspection of air lines and muffler media is recommended to maintain performance.
<b>Product Testing</b>
Each pump is tested before being packaged for shipment. White Knight recommends the flushing of each pump before servicing if water can contaminate the process.

### 3.2 PSD Installation Advantages

Head Pressure / Dead-Head
White Knight PSD pumps may be controlled by opening and closing the outlet of the pump and may be installed in any head pressure situation up to dead-head. Dead-head occurs when air supply pressure and the liquid line (head) pressure are equal. Dead-head conditions allow for no flow. Under dead-head conditions the PSD will cease to cycle (limiting wear) until conditions change allowing for flow.
Passing Solids
All damage caused by passing solids (wafer shards, etc.) is coverable under warranty when your pump is used in conjunction with a White Knight Catcher™ pre-pump filter.
Running Dry
White Knight PSD pumps are capable of running dry without damage other than normal wear to the pump. When a pump is run dry it cycles faster than normal, accelerating the rate of normal wear.

### 3.3 System and Pump Environment

Clean Dry Supply Air (CDA)
Operation of the point of 5 PSD24 requires class 4 quality air for particles, moisture, and oils. (maximum particle size 15 microns, 3° C Dew 5 mg/m³) per ISO8573 – 1.
Flammable Solvents
Any system used to pump flammable solvents should be properly grounded. A test from River’s Edge on using isolative pumps to pump flammable liquids indicated that the liquid itself must be grounded and that other procedures should be followed. A copy of the test is available upon request from White Knight.
Pumping Liquids Near Boiling Point
The boiling point of a liquid is reduced under vacuum (suction) conditions. Due to the vacuum caused by a pump, liquid could boil in the inlet line of the pump when it is not boiling in the tank (or other supply reservoir). Placing the pump as close as possible to the tank and with as little vertical lift as possible (the pump being flooded by gravity is ideal) minimizes boiling in the inlet line. Boiling of the liquid in the inlet line causes a pump to “race” and accelerates the wear of the pump. Boiling liquids may cause cavitation to occur. Damage to wearable or non-wearable components of the pump caused by cavitation is not covered under warranty.
Running a Submerged Pump
When running the PSD in submerged mode, the exhaust air must be sealed and redirected above the surface of the media. Take care that all pump parts (air side and wet side) are resistant to the media being used. It may be necessary to mount the pump to the bottom of the tank. Operating this pump while submerged requires use of a remote muffler adaptor kit.
Temperature
The PSD may be operated safely in low temperature applications. Take care to avoid freezing or crystallization of the fluid inside or outside of the pump. Running the pump at temperatures below freezing may accelerate the wear of the elastomer components within the pump. In applications where the media or pump temperature varies, torque values (tension) of the manifold and head bolts must be monitored. TE versions of the PSD Series pumps can be operated at temperatures up to 100°C (212° F).

### 3.4 Control and Monitoring Connections

- **PUMP MONITORING:** Pump monitoring can be performed by solid state pressure switch monitoring. This option is described on our website in the accessories section and is available for new orders and for retrofits in the field.

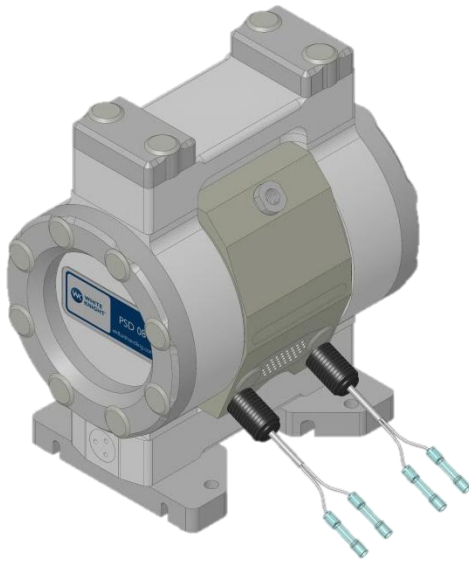

**Conductivity Leak Detection**

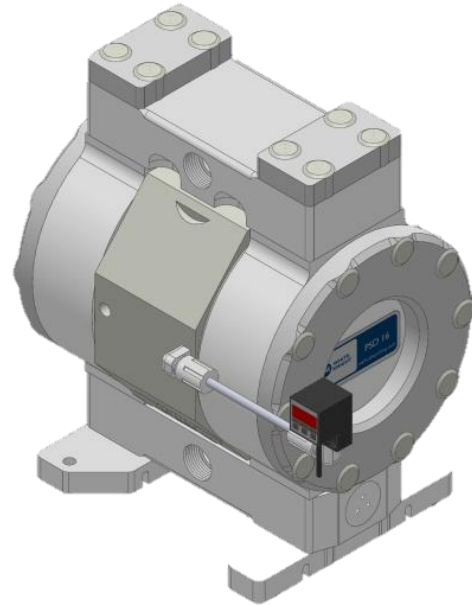

**Pressure Switch Stroke Detection**

- **Pump Control:** Run mode and flow rate are two of the items which the **CPT-1** can control/monitor.



### 3.5 PSD 24 Installation Instructions

1.



2.

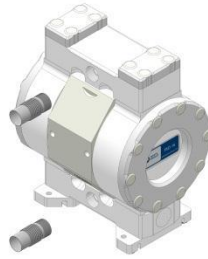

3.



Use appropriate air inlet adapter for 1/2" NPT

- Fix base plate to work station with four 3/8" or 10 mm bolts. (Bolts not included.)
- Attach 1-1/2" liquid fittings to pump. Excessive force may damage threads.
- Ensure airline is free of solids before attaching. Supply air via 1/2" NPT air fitting with flexible connection.

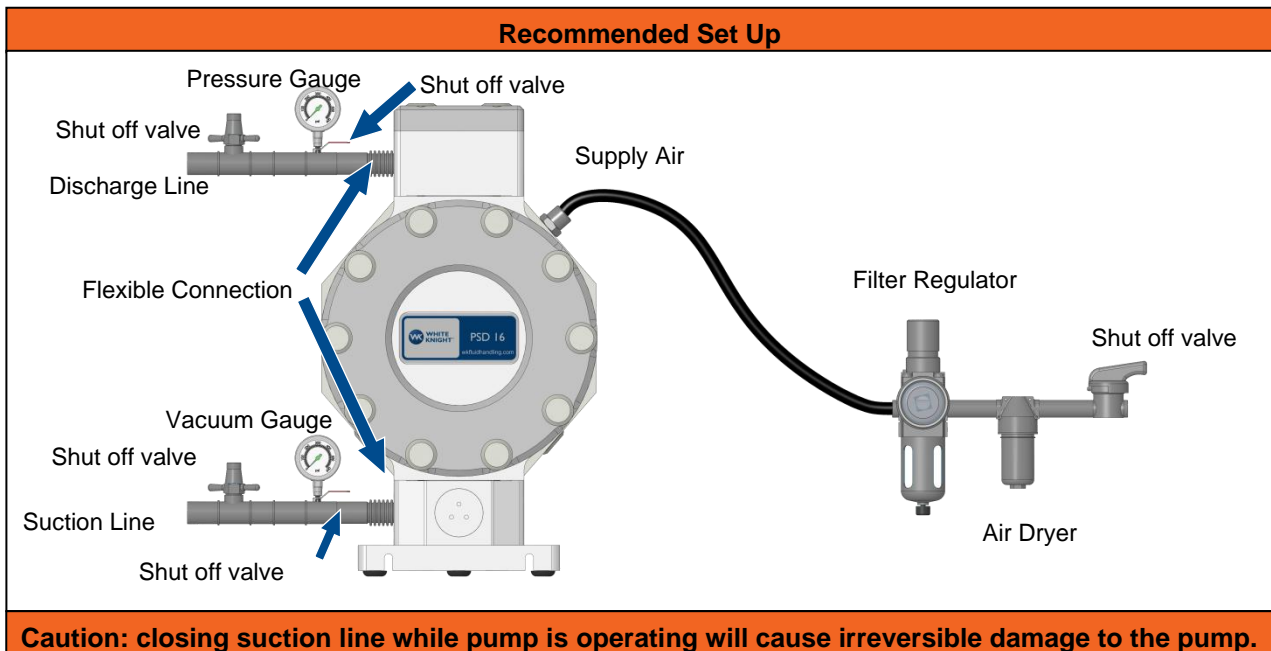
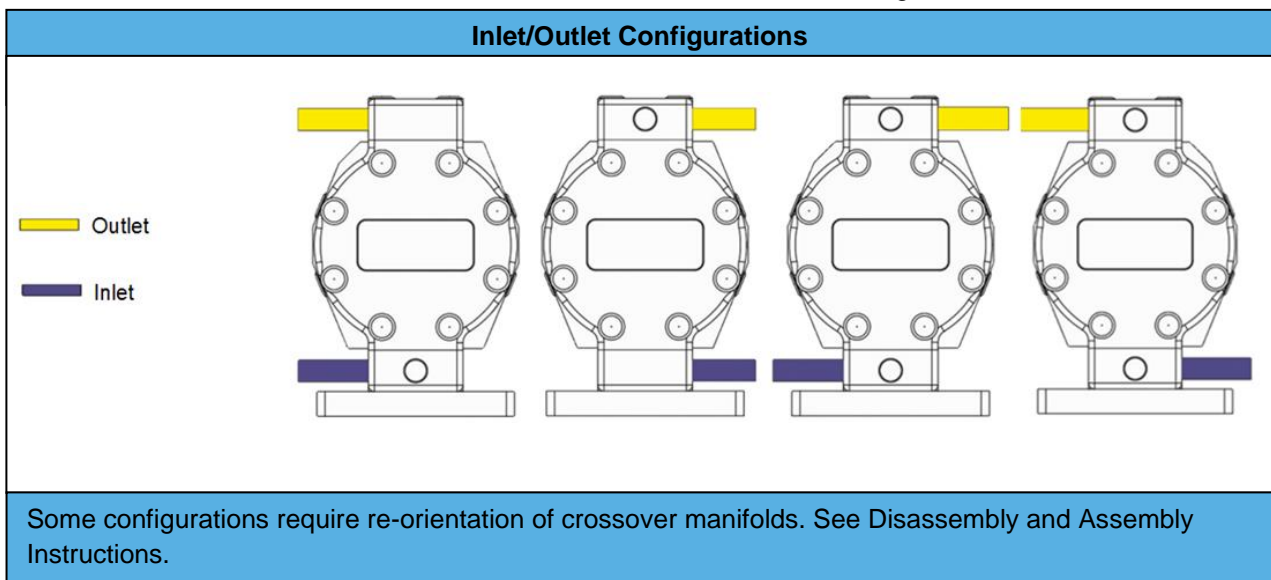

## 4 Pump Service & Rebuilds

### 4.1 PSD Ordering instructions

#### Standard Models

Part Number	Orifice Diameter	Liquid Connections
PSD24TE-OTN	1-1/2-in	Female NPT (same diameter as orifice)
PSD24TE-OTX00	1-1/2-in	WK Buttress connections (Fittings sold separately)

Contact support for revision or copy exact information.

#### Standard Features

- PTFE Liquid Path
- Polypropylene Body
- PTFE Check Balls
- Over-Molded PTFE/EPDM Diaphragms
- NPT Air Connections
- NPT or WK Buttress Liquid Connections

WK Buttress Connections feature Tongue-and-Groove Seals for improved reliability and reusability.

#### Compatible Fittings with WK Buttress Connections

Pump fittings are sold separately. Two fittings are required for operation.

Fitting Sizes		PSD24TE-OTX00
Flaretek Compatible	1 in	14510-PF-0018
	1-1/4 in	14510-PF-0017
Pillar S-300	1 in	14530-PF-0032
	1-1/4 in	14530-PF-0030
	1-1/2 in	14530-PF-0031
Primelock	1 in	14570-PF-0016
Tube Adapter	1-1/4 in	7120-PF-0015
	1-1/2 in	7120-PF-0016

## 4.2 Rebuild Kit Ordering Instructions

### PSD24 Rebuild Kits

Part Name	Part Number
PSD24 Dry Rebuild Kit	RBPSD24-1
PSD24 Alternate Dry Rebuild Kit (Air Motor)	RBPSD24-2
PSD24TE-OT Wet Rebuild Kit	RBPSD24TE-OT
PSD24TE-OT Combined Rebuild Kit	RBPSD24TE-OT-1*
PSD24TE-OT Alternate Combined Rebuild Kit	RBPSD24TE-OT-2**

\*Contains all parts of RBPSD24-1 and the applicable wet kit

\*\*Contains all parts of RBPSD24-2 and the applicable wet kit

#### Parts included in the RBPSD24-1 Rebuild Kit

Part Number	Description	Quantity
10040-PE-0007	Cap Plug for WK pump, PSD24	10
6140-FP-0007	Felt Muffler WK Pump, PSD24	4
10300-XX-0001	PTFE Lubricant, Squeeze Tube	1
14850-PT-0005	Spool/Sleeve Assembly	2

#### Parts included in the RBPSD24-2 Rebuild Kit

Part Number	Description	Quantity
10040-PE-0007	Cap Plug for WK pump, PSD24	10
6140-FP-0007	Felt Muffler WK Pump, PSD24	4
10080-EM-246-70	#246 Oring Seal, EPDM	4
10300-XX-0001	PTFE Lubricant, Squeeze Tube	1
14860-NP-0003	PSD24 Air Motor Assembly	1



**Parts included in the RBPSD24TE-OT Rebuild Kit**

Part Number	Description	Quantity
3200-TE-0003	Diaphragm for WK Pump, PSD24, PTFE	2
3300-SS-0005	Strike Plate for WK Pump, PSD24	2
4100-TE-0006	1-5/8" Check Ball for WK Pump, PSD24, PTFE	4
4137-TE-0006	Retainer, Ball, 1-5/8", PTFE	4
10040-PE-0007	Cap Plug for WK pump, PSD24	45
10080-TE-333	#331 O-ring Seal, PTFE	4
10050-MP-0003	Dring	4
4135-TE-0019	Bottom Manifold Wear seat, PSD24TE	2
4135-TE-0017	D-ring wear seat, PSD24TE	2
10080-EM-117-50	O-ring, 117, EPDM, 50 durometer	2
10050-UH-0007	Glide Seal - Shaft Seal	2
10300-XX-0001	PTFE Lubricant, Squeeze Tube	1

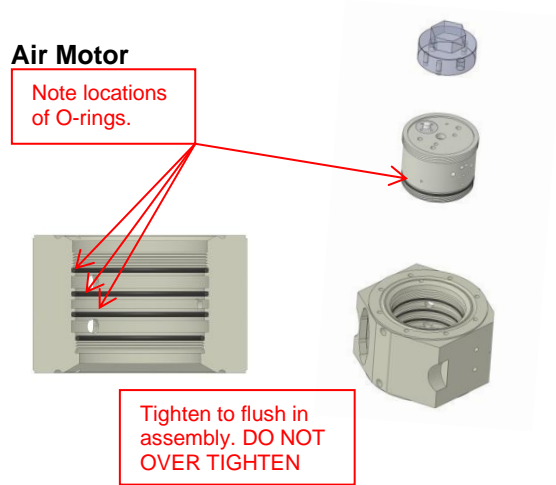

Air Motors do not need to be removed from the pump for service. However, complete air motors with all components (tested and certified) are available from White Knight. They can be removed and installed in the pump body as shown in the figure using the air motor pin wrench tool. (Rotate counter clockwise to remove.)

**Part Number for Air Motor Assembly:**

**14860-NP-0003**

### 4.3 Tools

Part Name	Part Number	QTY.
Pin Wrench $\frac{3}{4}$ " X $\frac{1}{8}$ " & $\frac{1}{2}$ " X $\frac{1}{8}$ "	12100-PV-0030	1
Pin Wrench $\frac{1}{2}$ " and 1" Air Motor*	12100-PV-0045	1

\*Air motor does not need to be removed to service pump. The air motor wrench is not included with the pump but is available from White Knight.

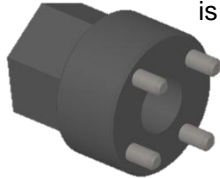

Four pin wrench used to remove/install the Sleeve Pilot Spool Assembly (included with pump). Hex is for use with 19 mm or  $\frac{3}{4}$ " socket. (12100-PV-0030)

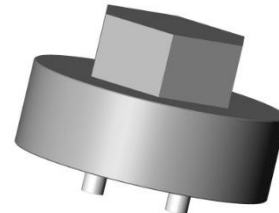

Pin Wrench for removing air motors from 1- $\frac{1}{2}$ " PSD pumps (Must purchase separately to remove air motor, not included with pump). (12100-PV-0045)

### 4.4 Torque Instructions

 Tie Bolts       Crossover Bolts

Tie bolts (purple) on both sides must be torqued **before** manifold bolts (blue) on top and bottom.

Torquing of head bolts should be done in a crossing fashion such as: 1, 6, 8, 3, 5, 10, 2, 7, 4, 9.



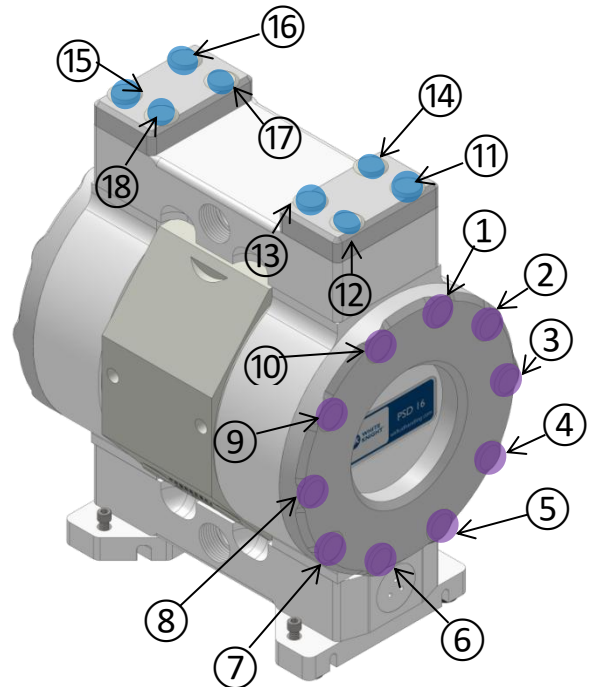

Torquing of manifold bolts should be done in a crossing fashion such as 13, 11, 12, 14, 17, 15, 18, 16.

Apply Loctite Antiseize Lubricant LB 8012 (or equivalent) to all bolts. This procedure must be followed for assembly and also re-Torquing of bolts.

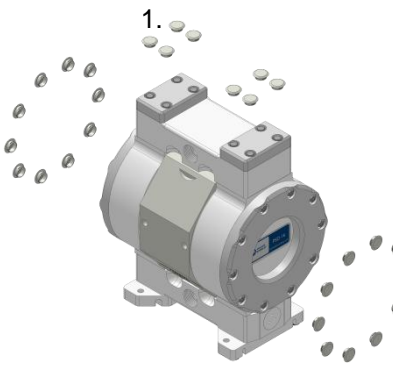
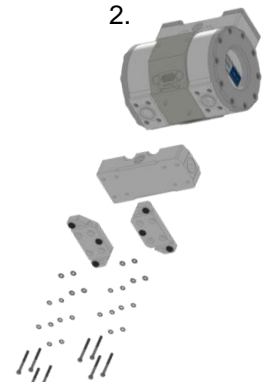

	Assembly Torque in-lbs. (kg-cm)
Tie Bolts	75 (86.4)
Manifold Bolts	60 (69.1)

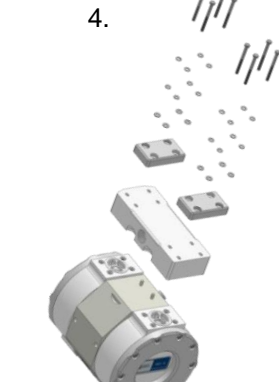
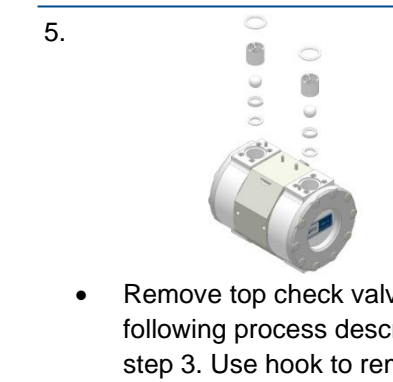
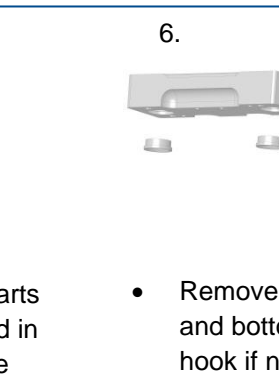
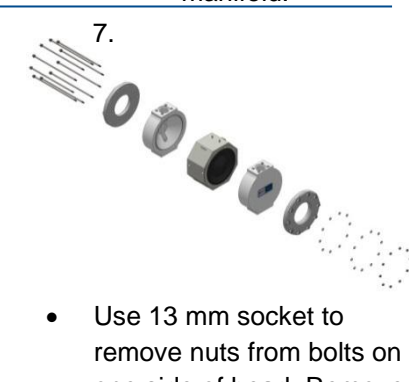
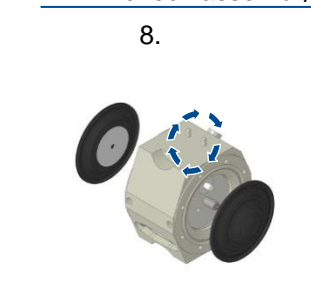
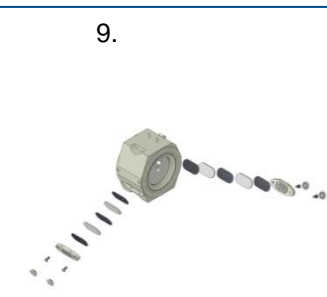
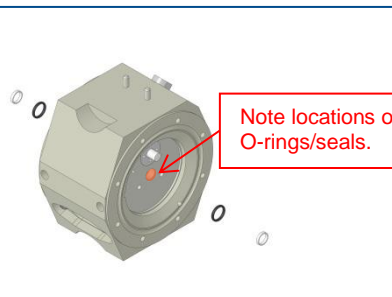
### 4.5 Disassembly instructions

- 
- Remove all plastic caps.
- 
- Use 13 mm socket to remove pump base feet and inlet manifold
- 
- Remove Top O-ring, and check valve parts. Without scratching the inner bore, use a hook to remove the check cages.
- 
- Use 13 mm socket to remove outlet manifold.
- 
- 
- Remove top check valve parts following process described in step 3. Use hook to remove wear surface placed below check assembly.
- 
- Remove wear surfaces in top and bottom manifolds. Use hook if necessary.
- 
- Use 13 mm socket to remove nuts from bolts on one side of head. Remove both heads.
- 
- 
- Remove diaphragms by peeling one back and turning it counter-clockwise. Slide the second diaphragm out with the shaft.
- 
- Use 4 mm Allen wrench to remove muffer cap. Remove poly felt muffer pads and inserts.
- 
- Remove the two glide seals seated in the shaft cavity. Then remove O-rings from the same slots. Take care to not damage the shaft bore or the O-ring grooves.
- 
- Use 19mm socket drive and pin wrench to remove pilot assembly. Repeat for other side.

### Servicing of Pump

Before servicing the pump make sure that the pump has been drained and cleaned so as to minimize the potential of physical damage and maximize the safety of service personnel.

## 4.6 Assembly Instructions

1.



- Insert pilot assembly into air motor and tighten with pin wrench using 9mm socket drive. Repeat for other side.

2.

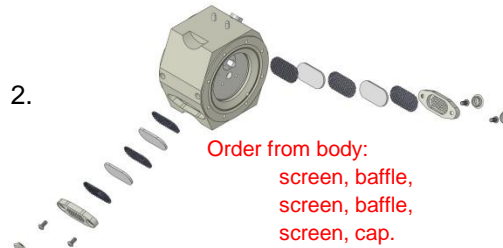

- Replace inserts and porous poly baffles. Secure muffler cap with screws using 4 mm Allen Wrench. Torque to 16 in-lbs. (18 kg-cm).

3.

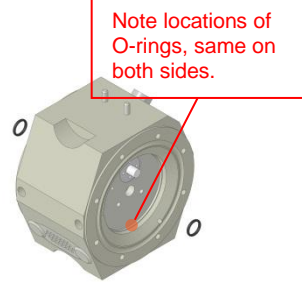

- Taking care to not damage shaft bore or O-ring grooves, replace the shaft O-rings.

4.



- Taking care to not damage the shaft bore or O-ring grooves, replace the shaft glide seals by pinching glide seal with needle nose pliers (rubber tipped) to form a kidney shape and insert into groove.

5.

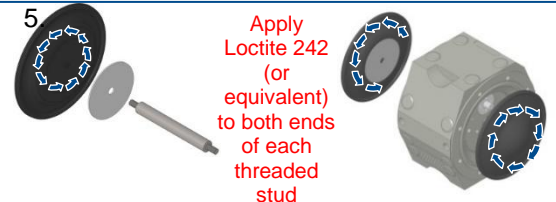

- Align strike plate and thread one diaphragm to the shaft and push it through the shaft bore. Align and thread the second diaphragm and plate onto the shaft. Make sure the diaphragms are snug on the shaft.

6.

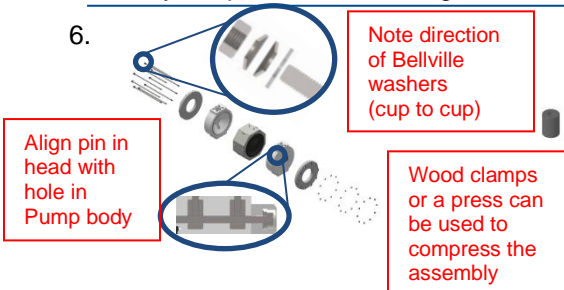

- Use tie rods to attach heads and retainer rings. Apply antiseize lubricant to tie rods. Install all rods but **do not tighten**. Verify that top and bottom rods pass through the manifold nuts placed in heads.

7.

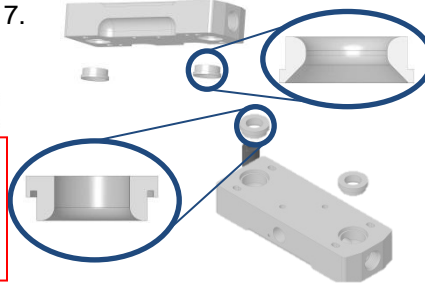

- Press wear-surfaces into grooves in manifolds. Note different parts for top and bottom manifolds.

8.



- Taking care to not damage the check bore areas, replace top check valve parts and O-rings. **NOTE ORDER OF VALVE ASSEMBLY**

9.

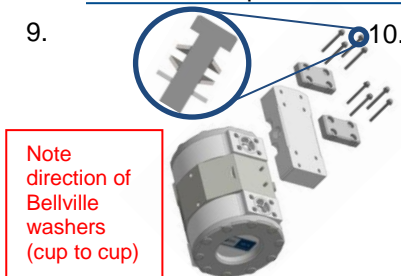

- Replace outlet manifold using 6mm socket. Apply antiseize lubricant to tie rods. **Do not tighten**.

10.



- Taking care to not damage the check bore areas; replace bottom check valve parts and O-rings. **NOTE ORDER OF CHECK VALVE ASSEMBLY**, different from top check valves.

11.

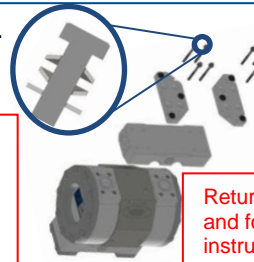

- Replace bottom crossover using 13mm socket. **Do not tighten**. Return to page 16 and follow torque instructions.

12.

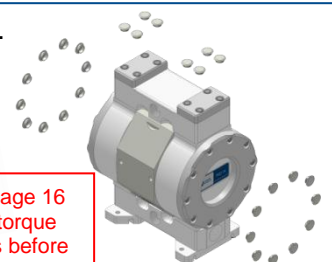

- Replace all plastic caps.

## 5 Accessories

**Remote Muffler Adaptor Kit-** (Not included with pump.)

### **Pump Catcher™**

- Inline options available.
- Large through holes to avoid loading.
- Filter may be removed without removing the **Catcher™** from the pump or the line.
- If a pump were damaged by passing solids while using the **Catcher™** it would be repaired under warranty.

## **Control & Monitoring Options**

### **Stroke Detection**

- Solid State Pressure Switch SP1

**Control Options** – Run mode and flow rate are a few of the items which the **CPT-1** can control/monitor.

## 6 Warranty

White Knight Fluid Handling follows strict procedures in all phases of manufacturing, assembly, and testing to ensure reliability of its products. Each pump is individually tested to assure its functional operation integrity.

White Knight Fluid Handling warrants the PSD24 pump, subassemblies and components to be free from defects in materials and workmanship to one year from date of start-up or 18 months from the date of shipment whichever applies. Failures due to misuse, abuse or any unauthorized disassembly of a White Knight<sup>®</sup> pump will nullify this warranty.

The PSD24 pump is warranted for up to 100 PSI air supply pressures. It is not covered under dry run condition. Wearable parts are not covered.

Due to the broad and ever-evolving applications for usage of White Knight<sup>®</sup> pumps we cannot guarantee the suitability of any pump component or subassembly for any particular or specific application. White Knight Fluid Handling shall not be liable for any consequential damage or expense arising from the use or misuse of its products in any application. Responsibility is limited solely to the replacement or repair of defective White Knight<sup>®</sup> pumps, components or subassemblies. All options to rebuild or replace aforementioned items shall remain under the judgment of White Knight Fluid Handling. Decisions as to the cause of failure shall be solely determined by White Knight Fluid Handling.

Prior written, faxed or emailed approval must be obtained from White Knight Fluid Handling before returning any pump component or subassembly for warranty consideration.

**THE FOREGOING WARRANTY IS EXCLUSIVE AND IN LIEU OF ALL OTHER WARRANTIES EXPRESSED OR IMPLIED INCLUDING ANY WARRANTIES OF SUITABILITY FOR ANY PARTICULAR PURPOSE. NO VARIATIONS OF THIS WARRANTY BY ANYONE OTHER THAN THE PRESIDENT OF WHITE KNIGHT FLUID HANDLING INC. IN A SELF-SIGNED AGREEMENT, SHALL BE HONORED OR CONSIDERED LEGALLY BINDING.**

## 7 Certification & Declaration of Conformity



### CERTIFICATE & DECLARATION OF CONFORMITY FOR CE MARKING

**Company contact details:**

White Knight Fluid Handling Inc.  
 187 E. 670 S., Kamas, Utah, 84036, USA

**White Knight Fluid Handling Inc. declares that their:**

**Bellows Pump Line**

PSA030, PSA060, PSA140, PSH030, PSH060, PSH140, PSU030, PSU060, PSU140, PSA025, PSA050, PFA030, PFA060, PFA140, PFH030, PFH060, PFH140, PFU030, PFU060, PFU140, PXA030, PXA060, PXA140, PXH030, PXH060, PXH140, PXU030, PXU060, PXU140

**Diaphragm Pump Line (Non Conductive)**

PSD04TE, PSD06TE, PSD08TE, PSD16TE, PSD24TE, PSD04UH, PSD06UH, PSD08UH, PSD16UH, PSD24UH

**Diaphragm Pump Line (Conductive)**

PSD04TC, PSD06TC, PSD08TC, PSD16TC, PSD24TC, PSD04UC, PSD06UC, PSD08UC, PSD16UC, PSD24UC

**Legacy Pump Line**

PLS30, PLS60, PLS120, PLX30, PLX60, PLX120, PX30, PX60, PX120, PLF30, PLF60, PLF120

**Metering Pumps**

PPM100, PEM100, PEM050

**Plastic Pumps**

PHC40-2, PPMC300

**are classified within the following EU Directives as applicable:**

Machinery Directive 2006/42/EC  
 Low Voltage Directive 2014/35/EU  
 Electromagnetic Compatibility Directive 2014/30/EU  
 RoHS 2 Directive 2011/65/EU

**and further conform with the following EU Harmonized Standards as applicable:**

EN 809:1998+A1:2009 EN 60204-1:2006 + A1:2009 EN 61000-6-2:2005 EN 61000-6-4:2007+A1:2011

**Dated:** 16 January 2017

**Position of signatory:** Product Manager **Name of Signatory:** Cory Ammon Simmons

**Signed below:** on behalf of White Knight Fluid Handling Inc.



## White Knight Support

187 E. 670 S.  
Kamas, UT 84036  
Phone: 435.783.6040  
Toll Free: 888.796.2476  
Fax: 435.783.6128

[support@wkfluidhandling.com](mailto:support@wkfluidhandling.com)

<https://wkfluidhandling.com/support/>