

RBA08 Owner's Manual

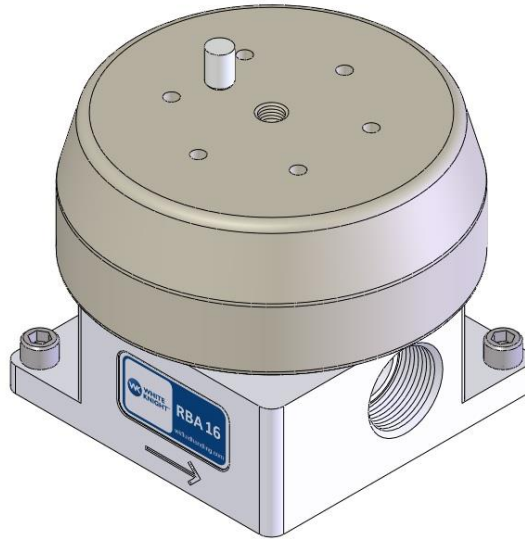

Contents

1. Specifications.....	2
1.1. Pressure to Temperature Limitations	2
1.2. Specification Grid.....	2
2. Operation	2
3. Dimensional	3
4. Installation Instructions	4

Version 1.0.0

White Knight back-pressure regulators offer remote piloting capability to maintain system pressure for high-purity chemical circulation loops and systems with multiple tool drops or dispense points. They feature fully-swept PTFE/PFA flow paths. They operate at up to 100°C (212°F) and 7 Bar (100 psi). They are air-spring loaded and highly accurate. RBA08 pressure regulators have 1/2-in connections. The flow through, or inner diameter of the tubing, is 3/8-in.

1. Specifications

1.1. Pressure to Temperature Limitations

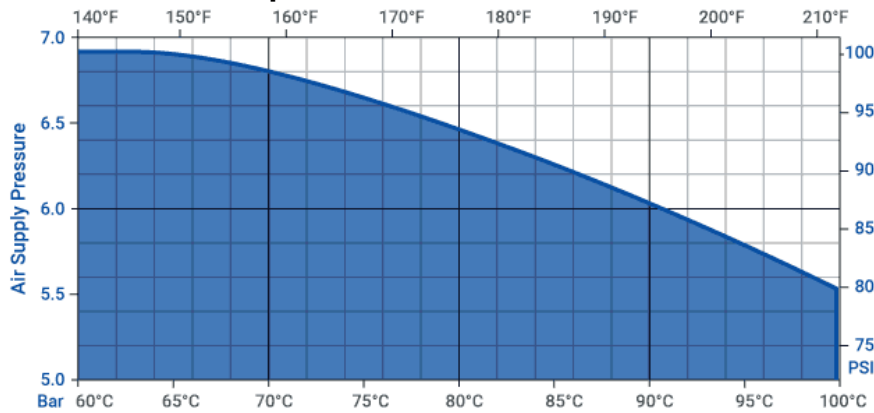

1.2. Specification Grid

Model	RBA08
Max Pressure	7 Bar (100 PSI)
Max Temperature	100 C (210 F)
ID Flow	3/8in
C _v	TBD

2. Operation

A single back-pressure regulator equalizes upstream fluid pressure across multiple discharge outlets.

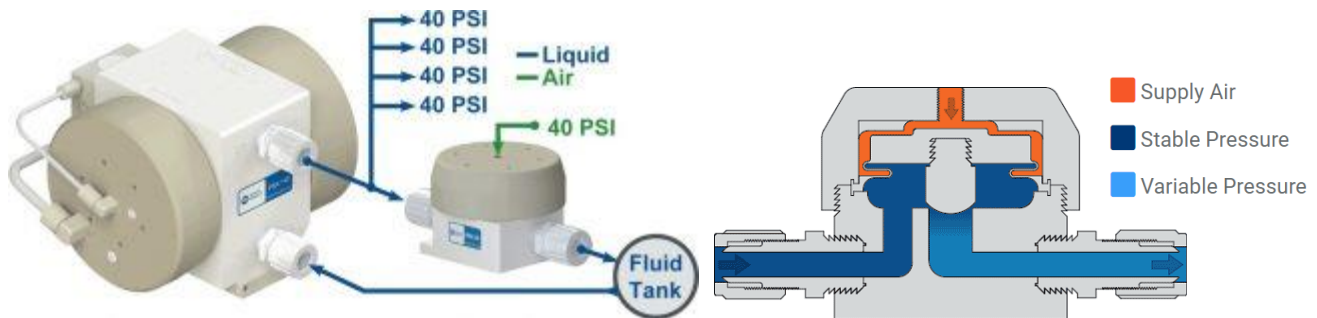

3. Dimensional

MAIN DIMENSIONS ARE INCHES
 [BRACKETED] DIMENSIONS ARE mm

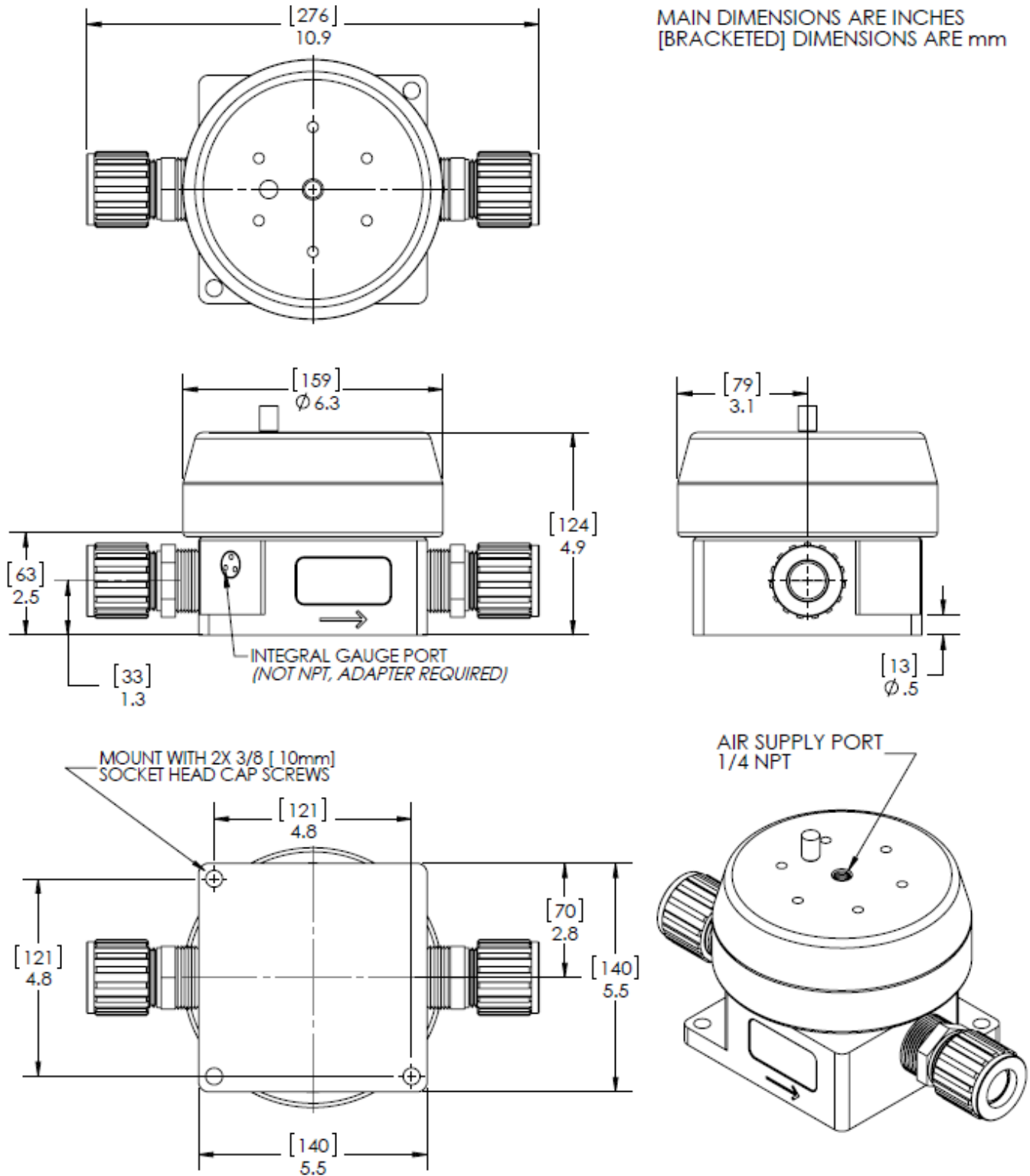

4. Installation Instructions

Ensure system is depressurized before service.

1.

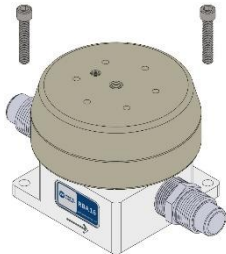

Attach Regulator to tool in predrilled and tapped holes for 3/8in (10mm) socket head cap screws.

2.

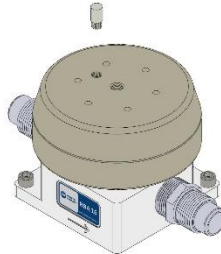

Attach Muffler or Plug to NPT port. Use of the muffler makes the unit more responsive to system changes. The plug reduces air use.

3.

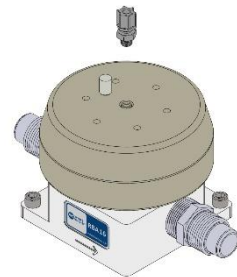

Attach air connection fitting.

4.

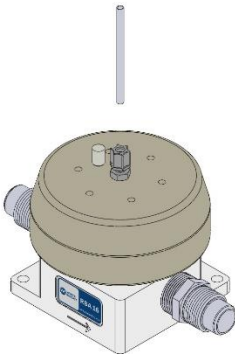

Attach air-line to device. Min 1/8in ID tubing.

5.

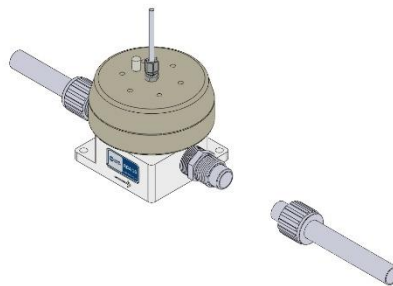

Loosely attach liquid connections.

6.

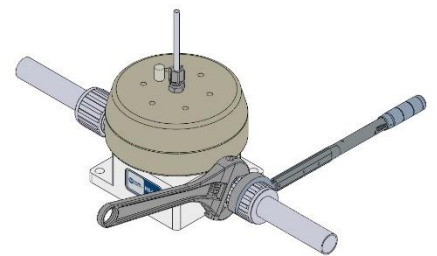

Torque liquid fittings to manufacturer spec. Use a backer wrench on fitting body.

