

RFA16 Owner's Manual



Contents

| | |
|--|---|
| 1. Specifications..... | 2 |
| 1.1. Pressure to Temperature Limitations | 2 |
| 1.2. Specification Grid..... | 2 |
| 2. Operation | 2 |
| 3. Dimensional | 3 |
| 4. Installation Instructions | 4 |

White Knight forward-pressure regulators offer remote piloting capability to maintain system pressure for high-purity chemical circulation loops and systems with multiple tool drops or dispense points. They feature fully-swept PTFE/PFA flow paths. They operate at up to 100°C (212°F) and 7 Bar (100 psi). They are air-spring loaded and highly accurate. Pressure regulators are available in 1/2-in, 3/4-in and 1-in models — determined by the connection size and outer diameter of the tubing. The flow through, or inner diameter of the tubing, is 1/8-in smaller than the nominal connection size.

1. Specifications

1.1. Pressure to Temperature Limitations

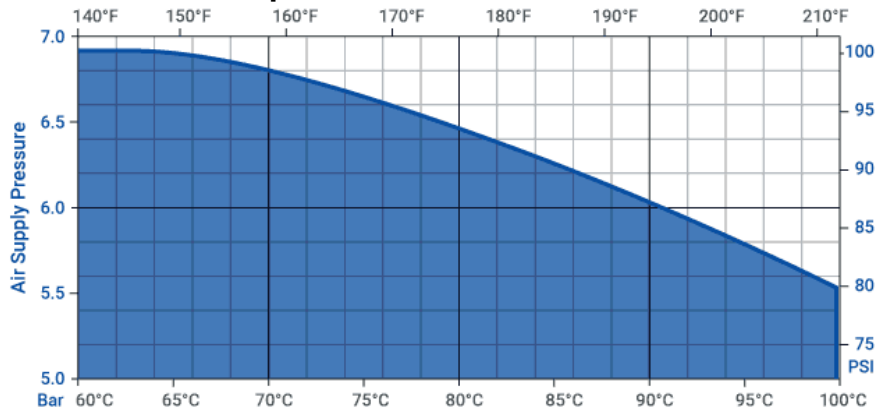

1.2. Specification Grid

| | |
|-----------------|-----------------|
| Model | RFA16 |
| Max Pressure | 7 Bar (100 PSI) |
| Max Temperature | 100 C (210 F) |
| ID Flow | 7/8in |
| C _v | 7.3 |

2. Operation

Forward pressure regulators control downstream fluid pressure. One regulator is required for each discharge pressure.

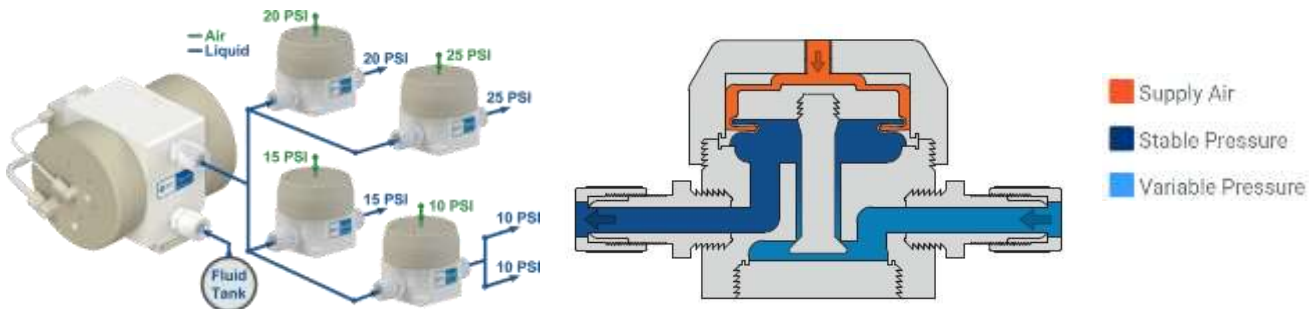

3. Dimensional

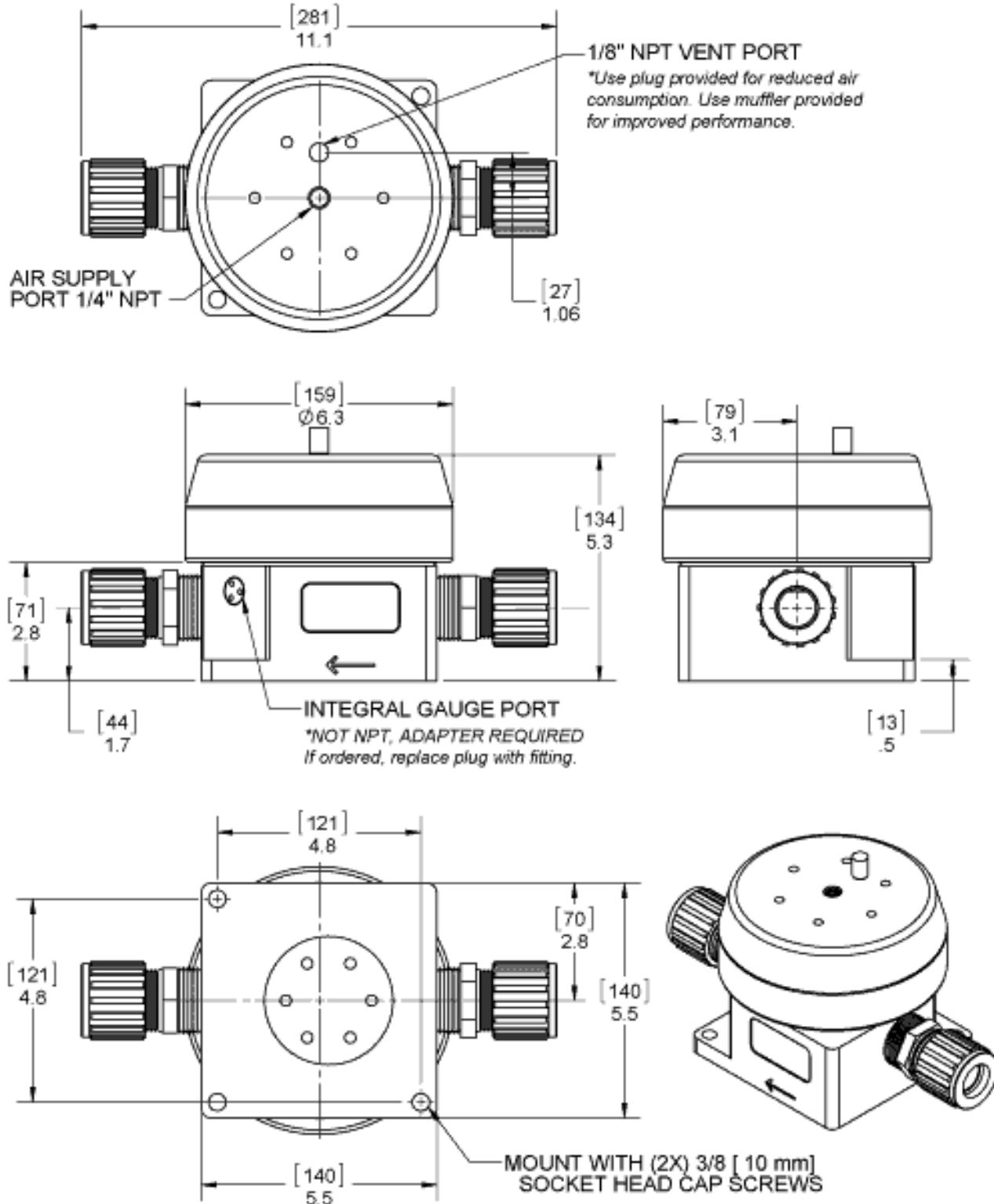

4. Installation Instructions

Ensure system is depressurized before service.

1.



Attach Regulator to tool in predrilled and tapped holes for 3/8in (10mm) socket head cap screws.

2.



Attach Muffler or Plug to NPT port. Use of the muffler makes the unit more responsive to system changes. The plug reduces air use.

3.



Attach air connection fitting.

4.

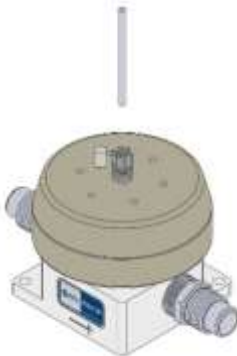

Attach air-line to device. Min 1/8in ID tubing.

5.

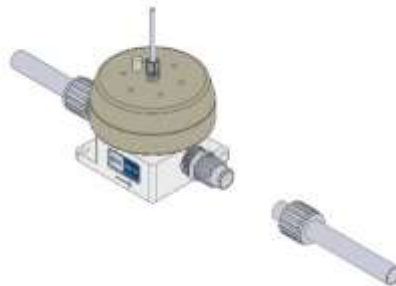

Loosely attach liquid connections. Ensure that liquid flows in the same direction as the arrow below the label.

6.



Torque liquid fittings to manufacturer spec. Use a backer wrench on fitting body.

