



Dispense Chemical With Absolutely No Pulsation

White Knight pressure vessels provide laminar flow at the point of use and serve as chemical holding or mixing tanks. They are available in 4-in diameters with various connectable pipe lengths. They feature configurable port connections, and their PTFE manifold ends can be designed with more ports or integrated valves. Capacitive sensor ports for high- and low-liquid levels are standard. Mid-liquid level sensing adapters are also available.

Advanced Technologies

Process-safe PTFE, PFA flow paths

Eight connection ports for monitoring, fill, and dispense

Extruded PFA pipe with threaded connections

Leak-Free Tongue-and-Groove seals

Up to 7 Bar (100 psi) pressures

Up to 100°C (212°F) temperatures

Capacity up to 6 liters

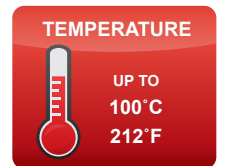
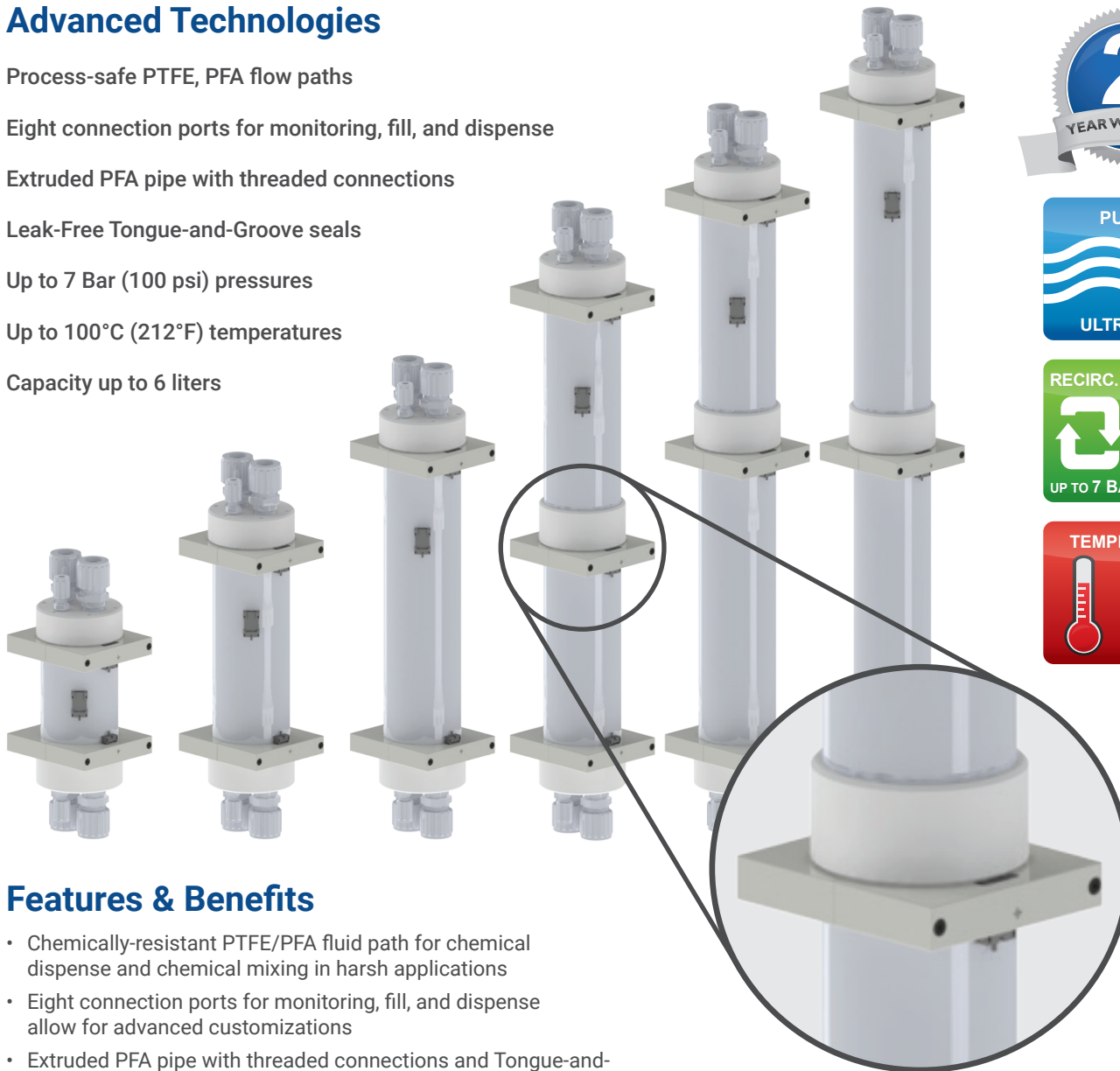

Features & Benefits

- Chemically-resistant PTFE/PFA fluid path for chemical dispense and chemical mixing in harsh applications
- Eight connection ports for monitoring, fill, and dispense allow for advanced customizations
- Extruded PFA pipe with threaded connections and Tongue-and-Groove seals offer easy setup and maintenance without welding
- Pressure capabilities up to 7 Bar (100 psi) provide high flow rates and allow for faster processes
- Operates in applications up to 100°C (212°F)
- Models capable of up to 6 liters
- Two-year warranty

Connectable PFA Pipes

Connectable pipes lengths offer capacity customization. The threaded connections feature leak-free tongue-and-groove seals.

<https://wkfluidhandling.com/pressure-vessels/>



PV4 Dimensions

inches [mm]

PV4 Dimensions

mm (in)

	A (without diptube)	A (with diptube)	B
1 liter	254 (10.0)	270 (10.6)	142 (5.6)
2 liter	393 (15.5)	409 (16.1)	280 (11.1)
3 liter	531 (20.9)	547 (21.5)	419 (16.5)
4 liter	755 (29.7)	771 (30.4)	643 (25.3)
5 liter	894 (35.2)	910 (35.8)	782 (30.8)
6 liter	1033 (40.7)	1049 (41.3)	920 (39.0)

* Fitting height will vary according to type of fitting used.
 Other fitting options include Super 300 Pillar, Weldable, FNPT.
 Unused parts are plugged with Tongue-and-Groove seal plug.

Capacitive high/low
 liquid level sensors

**DETAIL A
 SCALE 1 : 2**

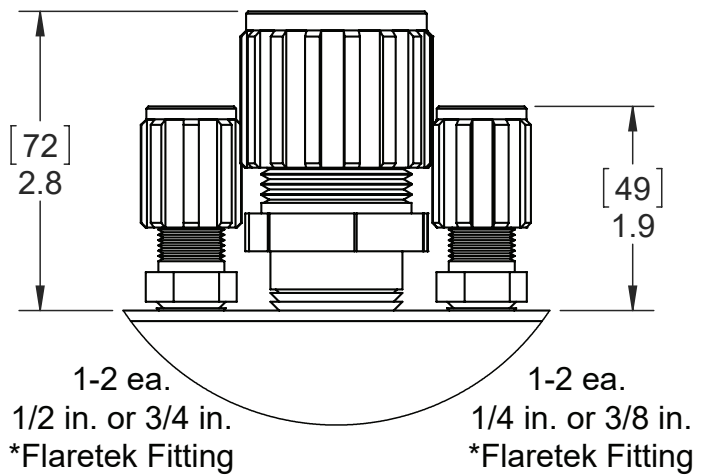
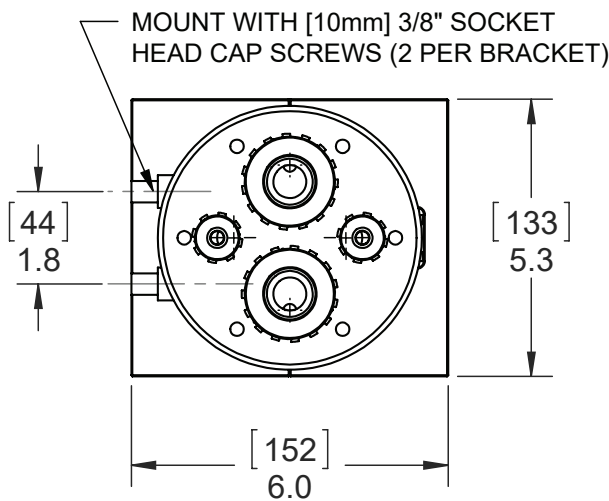
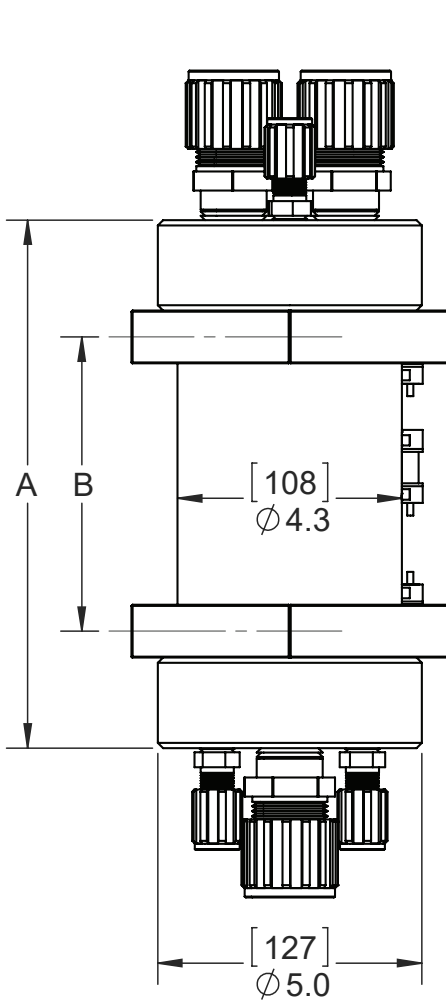

<https://wkfluidhandling.com/pressure-vessels/>